



VLT[®] Active Filter AAF 005 Operating Instructions

Contents

1 How to Read these Operating Instructions	3
1.1.1 Copyright, Limitation of Liability and Revision Rights	3
1.1.3 Symbols	3
2 Safety	4
2.1.2 General Warning	4
2.1.3 Before Commencing Repair Work	4
2.1.4 Special Conditions	5
2.1.5 Avoid Unintended Start	5
2.1.6 IT Mains	5
3 Introduction to VLT Active Filter AAF 005	6
3.1.1 Working Principle	6
3.1.2 Filter Configurator	7
3.1.3 Ordering Form Type Code	8
4 How to Install	9
4.1 How to Get Started	9
4.2 Pre-installation	10
4.2.1 Planning the Installation Site	10
4.2.2 Receiving the Active Filter	10
4.2.3 Transportation and Unpacking	10
4.2.4 Lifting	11
4.2.5 Mechanical Dimensions	12
4.3 Mechanical Installation	15
4.3.3 Terminal Locations - Frame size D	16
4.3.4 Terminal Locations - Frame size E	16
4.3.5 Cooling and Airflow	16
4.4 Field Installation of Options	20
4.4.1 Installation of Input Plate Options	20
4.4.2 Installation of Mains Shield for Active Filters	20
4.5 Electrical Installation	20
4.5.1 Current Transformer (CT)	20
4.5.2 Power Connections	24
4.5.8 Mains Connection	29
4.5.10 Power and Control Wiring for Unscreened Cables	29
4.5.11 Fuses	30
4.5.13 Control and CT Cable Routing	30
4.5.15 Electrical Installation, Control Terminals	32
4.6.1 Electrical Installation, Control Cables	33

4.6 Final Set-Up and Test	35
5 How to Operate the Active Filter	37
5.1.1 How to Operate Graphical LCP (GLCP)	37
5.1.6 Tips and Tricks	41
6 How to Programme	44
6.2.1 Main Menu	48
6.2 Parameter Lists	70
6.3.1 Default settings	70
6.3.2 Operation/Display 0-**	71
6.3.3 Digital In/Out 5-**	72
6.3.4 Comm. and Options 8-**	72
6.3.5 Special Functions 14-**	73
6.3.6 FC Information 15-**	74
6.3.7 Data Readouts 16-**	75
6.3.8 AF Settings 300-**	76
6.3.9 AF Readouts 301-**	76
7 RS-485 Installation and Setup	77
7.1 Network Configuration	78
7.2 FC Protocol Message Framing Structure	79
7.3 How to Access Parameters	82
8 General Specifications	84
8.1 Electrical Data	84
8.1.1 Power Rating	84
9 Troubleshooting	88

1 How to Read these Operating Instructions

1.1.1 Copyright, Limitation of Liability and Revision Rights

This publication contains information proprietary to Danfoss. By accepting and using this manual the user agrees that the information contained herein will be used solely for operating equipment from Danfoss or equipment from other vendors provided that such equipment is intended for communication with Danfoss equipment over a serial communication link. This publication is protected under the Copyright laws of Denmark and most other countries.

Danfoss does not warrant that a software program produced according to the guidelines provided in this manual will function properly in every physical, hardware or software environment.



Although Danfoss has tested and reviewed the documentation within this manual, Danfoss makes no warranty or representation, neither expressed nor implied, with respect to this documentation, including its quality, performance, or fitness for a particular purpose.

In no event shall Danfoss be liable for direct, indirect, special, incidental, or consequential damages arising out of the use, or the inability to use information contained in this manual, even if advised of the possibility of such damages. In particular, Danfoss is not responsible for any costs, including but not limited to those incurred as a result of lost profits or revenue, loss or damage of equipment, loss of computer programs, loss of data, the costs to substitute these, or any claims by third parties.

Danfoss reserves the right to revise this publication at any time and to make changes to its contents without prior notice or any obligation to notify former or present users of such revisions or changes.

1.1.2 Software Version and Approvals

AAF 005 VLT Active Filter
Software version: 1.00

This manual can be used with all VLT Active Filters with software version 1.00.
The software version number can be found in parameter 15-43 and 15-61 for the control and filter card respectively.

1.1.3 Symbols

Symbols used in these Operating Instructions.

NOTE
Indicates something to be noted by the reader.

Indicates a general warning.

Indicates a high-voltage warning.

* Indicates default setting

2 Safety

2.1.1 Safety Note



WARNING!

The voltage of the Active Filter is dangerous whenever connected to mains. Incorrect installation of the filter or options may cause damage to the equipment, serious personal injury or death. Consequently, the instructions in this manual, as well as national and local rules and safety regulations, must be complied with.

Safety regulations

1. The Filter must be disconnected from mains if repair work is to be carried out. Check that the mains supply has been disconnected and that the necessary time has passed before removing mains plugs.
2. The [STOP/RESET] key on the control panel does not disconnect the equipment from mains and is thus not to be used as a safety switch.
3. Correct protective earthing of the equipment must be established and the user must be protected against supply voltage in accordance with applicable national and local regulations.
4. The earth leakage currents are higher than 3.5 mA.
5. Do not remove the plugs for the mains supply while the filter is connected to mains. Check that the mains supply has been disconnected and that the necessary time has passed before removing mains plugs.
6. Please note that the filter has voltage inputs other than L1, L2 and L3, when external 24 V DC have been installed. Check that all voltage inputs have been disconnected and that the necessary time has passed before commencing repair work.

Installation at high altitudes

NOTE

At altitudes above 3 km, please contact Danfoss Drives regarding PELV

2.1.2 General Warning



WARNING!

Touching the electrical parts may be fatal - even after the equipment has been disconnected from mains. Before touching any potentially live parts of the unit, wait at least as follows:

380 - 480 V, 190A-310A, wait at least 20 minutes.

380 - 480 V, 400A-500A, wait at least 40 minutes.

Shorter time is allowed only if indicated on the nameplate for the specific unit. Be aware that there may be high voltage on the DC links even when the Control Card LEDs are turned off. A red LED is mounted on a circuit board inside the active filter to indicate the DC bus voltages. The red LED will stay lit until the DC link is 50 Vdc or lower.



CAUTION!

Leakage current

The earth leakage current from the filter exceeds 3.5mA. According to IEC 61800-5-1 a reinforced Protective Earth connection must be ensured by means of an PE wire - with the same cable cross section as the Mains wiring - must be terminated separately.

Residual Current Device

This product can cause a D.C. current in the protective conductor. Where a residual current device (RCD) is used for extra protection, only an RCD of Type B (time delayed) shall be used on the supply side of this product. Protective earthing of the filter and the use of RCD's must always follow national and local regulations.

2.1.3 Before Commencing Repair Work



WARNING!

Hazardous Voltage!

1. Disconnect the filter from mains
2. Wait at least the amount of time indicated in section General Warning above

Failure to follow recommendations could result in death or serious injury.

2.1.4 Special Conditions

Electrical ratings:

The rating indicated on the nameplate of the active filter is based on a typical 3-phase mains power supply, within the specified voltage, current and temperature range, which is expected to be used in most applications.

The unit also support other special applications, which affect the electrical ratings of the filter. Special conditions which affect the electrical ratings might be:

- High temperature applications which require derating of the electrical ratings
- High altitude installation which require derating of the electrical ratings
- Marine applications with more severe environmental conditions

Consult the relevant clauses in these instructions for information about the electrical ratings.

Installation requirements:

The overall electrical safety of the active filter requires special installation considerations regarding:

- Fuses and circuit breakers for over-current and short-circuit protection
- Selection of power cables (mains and relays)
- Grid configuration (IT,TN, grounded leg, etc.)
- Safety of low-voltage ports (PELV conditions)

Consult the relevant clauses in these instructions for information about the installation requirements.

2.1.5 Avoid Unintended Start

NOTE

While the active filter is connected to mains, the device can be started/stopped using digital commands, bus commands, references or via the Local Control Panel.

- **Disconnect the unit from mains whenever personal safety considerations make it necessary to avoid unintended start.**
- **To avoid unintended start, always activate the [OFF] key before changing parameters.**
- **Unless terminal 37 is turned off, an electronic fault, temporary overload, a fault in the mains supply may cause a stopped filter to start.**

2.1.6 IT Mains

NOTE

IT mains

Do not connect the unit with RFI-filters to mains supplies with a voltage between phase and earth of more than 440 V for 400 V.

For 400 V IT mains and delta earth (grounded leg), mains voltage may exceed 440 V between phase and earth.

Par. 14-50 RFI Filter can be used to disconnect the internal RFI capacitors from the RFI filter to ground.

2.1.7 Disposal Instruction

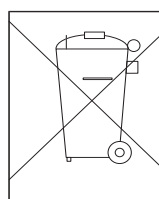

Equipment containing electrical components must not be disposed of together with domestic waste.

It must be separately collected with electrical and electronic waste according to local and currently valid legislation.

3 Introduction to VLT Active Filter AAF 005

3

3.1.1 Working Principle

VLT Active Filter AAF 005 is a device for harmonics and reactive current mitigation. The unit is designed for installation in various applications or combined with a VLT frequency converter as a packaged low harmonic drive solution. The AAF measures the current signal via external transducers and counter acts the unwanted elements of the measured current. The unwanted elements are programmable via the LCP. The Active filter can compensate all harmonics until 40th harmonics at the same time in an overall compensation mode or individual harmonics down to specified value set via the LCP. The unit is also capable of correcting reactive currents and so make the current get in phase with the voltage giving a displacement power factor close to 1. Finally the unit will also try to balance out the current loads on the three installed filters to reassure that all phases are loaded identically when the filter is in overall compensation mode.

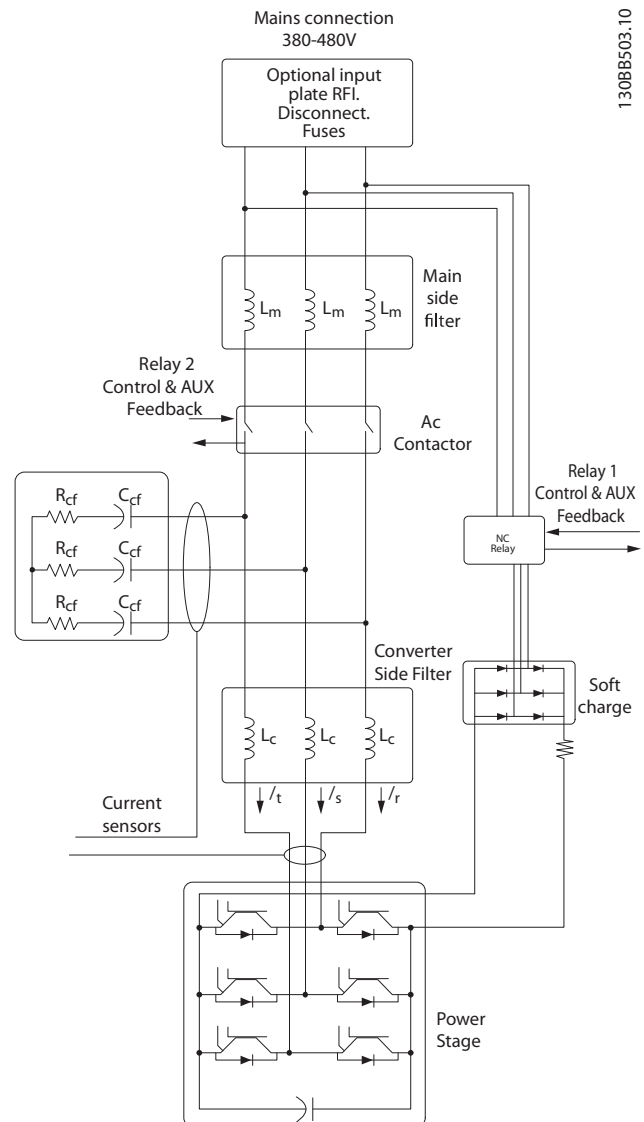

3.1.2 Filter Configurator

It is possible to design an Active Filter according to the application requirements by using the ordering number system. For the Active filter AAF 005 Series, you can order standard filters and filters with integral options by sending a type code string describing the product to the local Danfoss sales office, i.e.:

AAF 005A190T4E21H2xGCXXSXXXXAxBXCFXXDX

The meaning of the characters in the string can be located in the following pages containing the ordering numbers and option settings. In the example above a standard 190A Active filter is chosen in an IP21 enclosure for a 380-480V net. From the Internet based configurator, you can configure the right filter for the right application and generate the type code string. The configurator will automatically generate an eight-digit sales number to be delivered to your local sales office. Furthermore, you can establish a project list with several products and send it to a Danfoss sales representative. The configurator can be found on the global Internet site: www.danfoss.com/drives.

Filters will automatically be delivered with a language package relevant to the region from which it is ordered. Four regional language packages cover the following languages:

Language package 1

English, German, French, Danish, Dutch, Spanish, Swedish, Italian and Finnish.

Language package 2

English, German, Chinese, Korean, Japanese, Thai, Traditional Chinese and Bahasa Indonesian.

Language package 3

English, German, Slovenian, Bulgarian, Serbian, Romanian, Hungarian, Czech and Russian.

Language package 4

English, German, Spanish, English US, Greek, Brazilian Portuguese, Turkish and Polish.

To order filters with a different language package, please contact your local sales office.

3.1.3 Ordering Form Type Code

1	2	3	4	5	6	7	8	9	10	11	12	13	14	15	16	17	18	19	20	21	22	23	24	25	26	27	28	29	30	31	32	33	34	35	36	37	38	39
A	A	F	0	0	5	A				T	4	E			H		x	G	C		x	x	S	x	x	x	x	A	x	B	x	C	x	x	x	x	D	x

130BB504.10

3

		Possible choice
Product groups	1-3	AAF
Series	4-6	005
Current rating	7-10	A190: 190Amp A250: 250Amp A310: 310Amp A400: 400Amp A500: 500Amp
Phases	11	T: Three Phases
Mains Voltage	12	4: 380-480V AC
Enclosure	13-15	E21: IP21/Nema Type1 E5H: Hybrid IP54, IP21 magnetics, IP54 electronics E2M: IP21/Nema Type1 with mains shield E5G: Hybrid IP54 with mains shield
RFI filter	16-17	H2: RFI filter, Class A2 (standard) H4: RFI filter, Class A1 (optional)
Display (LCP)	19	G: Graphical Local Control Panel (LCP)
Coating PCB	20	C: Coated PCB
Mains option	21	X: No mains option 3: Mains disconnect and fuse 7: Fuse
Adaptation A	22	Reserved
Adaptation B	23	Reserved
Software release	24-27	Reserved
Software language	28	Reserved
A options	29-30	AX: No A option
B options	31-32	BX: No B option
C-option configuration	33-37	CFxxx: CO-option occupied with Active Filter control card
D options	38-39	DX: No Options

4 How to Install

4.1 How to Get Started

This chapter covers mechanical and electrical installations to and from power terminals and control card terminals. Electrical installation of *options* is described in the relevant Operating Instructions.

4.1.1 How to Get Started

The active filter is designed to achieve a quick and EMC-correct installation by following the steps described below.



WARNING!

Read the safety instructions before installing the unit. Failure to follow recommendations could result in death or serious injury.

Mechanical Installation

- Mechanical mounting

Electrical Installation

- Connection to Mains and Protecting Earth
- CT connection and cables
- Fuses and circuit breakers
- Control terminals - cables

Quick Setup

- Local Control Panel of filter
- Programming

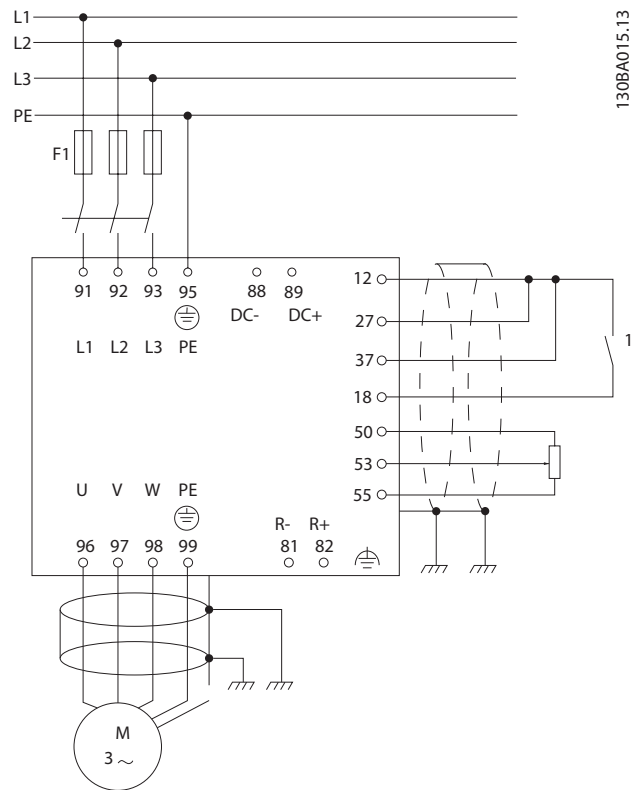

Illustration 4.1: Diagram showing basic installation including mains, start/stop key, and potentiometer for speed adjustment.

130BA015.13

4.2 Pre-installation

4.2.1 Planning the Installation Site

NOTE

Before performing the installation it is important to plan the installation of the Filter. Neglecting this may result in extra work during and after installation.

Select the best possible operation site by considering the following (see details on the following pages):

- Ambient temperature conditions
- Altitude at installation point
- Installation and compensation method
- How to cool the unit
- Position of the Active Filter
- CT installation point and possibility to reuse existing CT's
- Cable routing and EMI conditions
- Ensure the power source supplies the correct voltage and frequency
- If the unit is without built-in fuses, ensure that the external fuses are rated correctly.

4.2.2 Receiving the Active Filter

When receiving the unit please make sure that the packaging is intact, and be aware of any damage that might have occurred to the unit during transport. In case damage has occurred, contact immediately the shipping company to claim the damage.

NOTE

Damaged packaging can indicate a too rough transportation which might have resulted in inside failures of the unit. Even though the unit from the outside seems to be intact make sure to claim the damage

4.2.3 Transportation and Unpacking

Before unpacking the Active Filter it is recommended that it is located as close as possible to the final installation site. Keep the Filter on the pallet and boxed, as long as possible to avoid scratches and dents.

4.2.4 Lifting

Always lift the unit in the dedicated lifting eyes. For all D and E frames, use a bar to avoid bending the lifting holes.

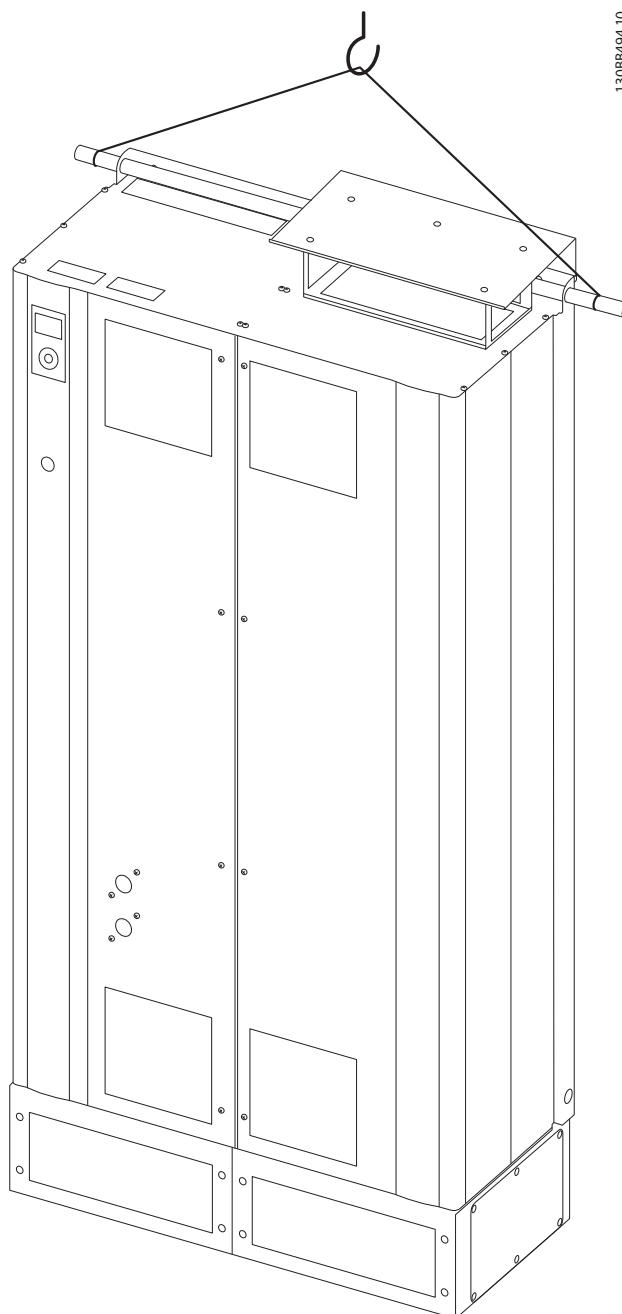

Illustration 4.2: Recommended lifting method, frame sizes D and E.

NOTE

The lifting bar must be able to handle the weight of the unit. See *Mechanical Dimensions* for the weight of the different frame sizes. Maximum diameter for bar is 2.5 cm (1 inch). The angle from the top of the unit to the lifting cable should be 60° or greater.

NOTE

Note the plinth is provided in the same packaging as the filter but is not attached to frame during shipment. The plinth is required to allow airflow to the unit to provide proper cooling. The plinth of the D and E-frames filters should be mounted before the unit is lifted to its final position. The angle from the top of the unit to the lifting cable should be 60° or greater.

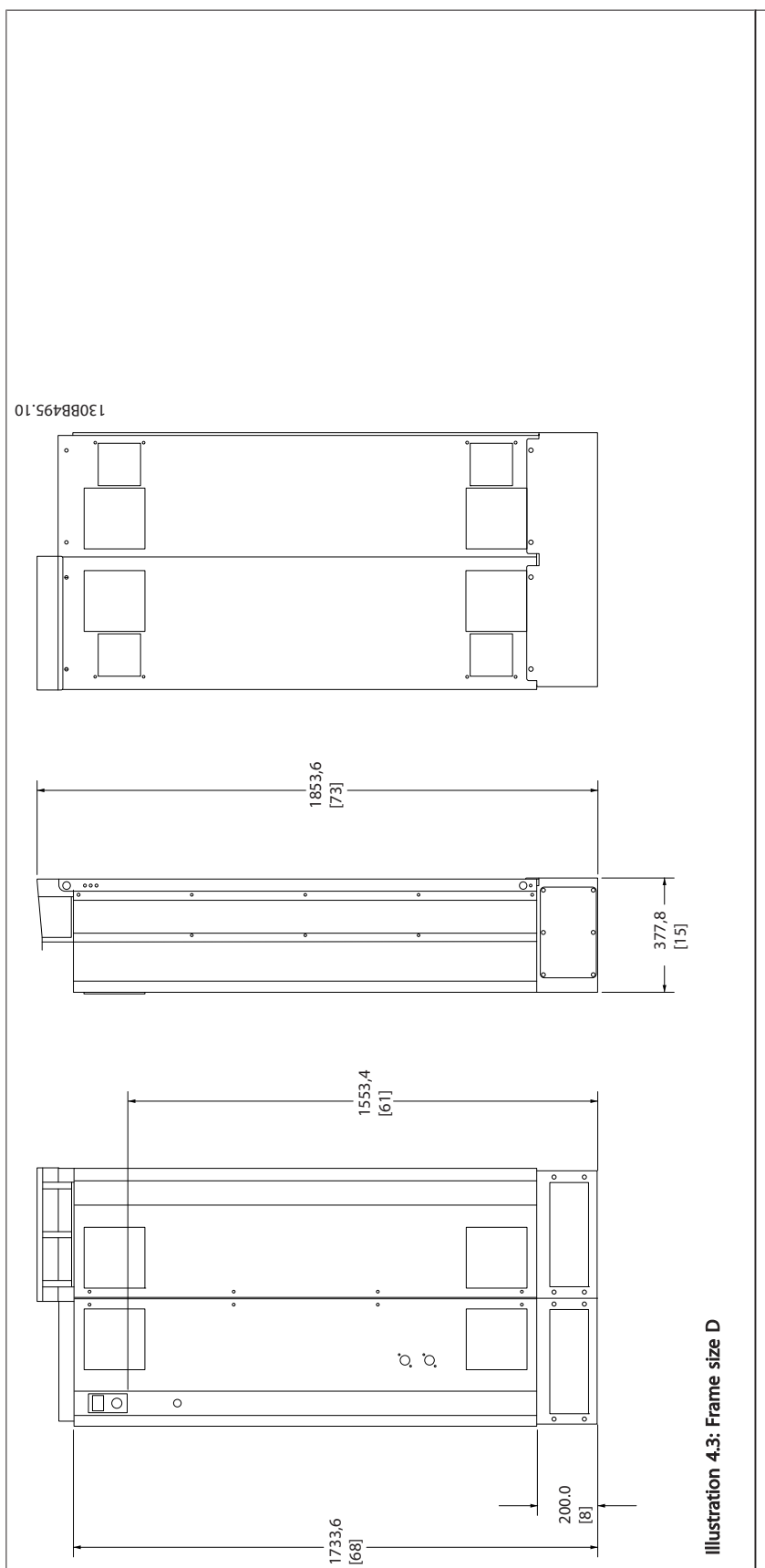

4.2.5 Mechanical Dimensions

4

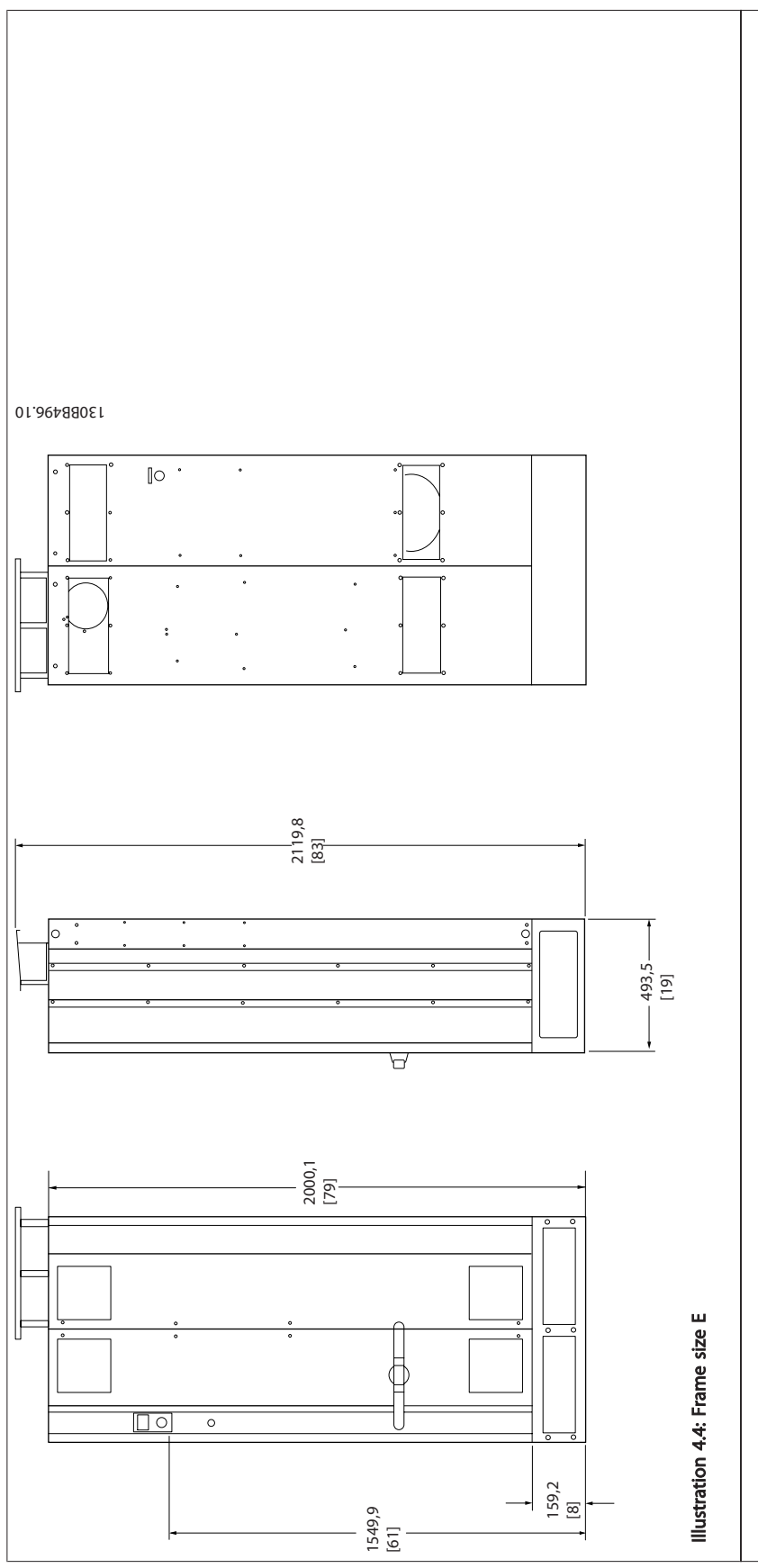



4

Mechanical dimensions and rated power			
Frame size		D	E
			
Enclosure protection	IP	21/54*	21/54*
	NEMA	Type 1	Type 1
Nominal current rate		190 A	250-310 A
Shipping Dimensions	Height	1892 mm	2111 mm
	Width	1118 mm	1118 mm
	Depth	947 mm	947 mm
Filter Dimensions	Height	1740 mm	2000
	Width	850 mm	850
	Depth	380 mm	494
	Max Weight	293 kg	352 kg
* Hybrid IP54 electronics, IP21 magnetics			

4.3 Mechanical Installation

Preparation of the mechanical installation of the filter must be done carefully to ensure a proper result and to avoid additional work during installation. Start taking a close look at the mechanical drawings in section 4.2.5 to become familiar with the space demands.

4.3.1 Tools Needed

To perform the mechanical installation the following tools are needed:

- Drill with 10 or 12 mm drill
- Tape measure
- Screw driver
- Wrench with relevant metric sockets (7-17 mm)
- Extensions to wrench
- Sheet metal punch for conduits or cable glands
- Lifting bar to lift the unit (rod or tube max. Ø 25 mm (1 inch), able to lift minimum 1000 kg).
- Cor other lifting aid to place the unit in position
- Torx T50 tool

4.3.2 General Considerations

Space

Ensure proper space above and below the unit to allow airflow and cable access. In addition space in front of the unit must be considered to enable opening of the door of the panel.

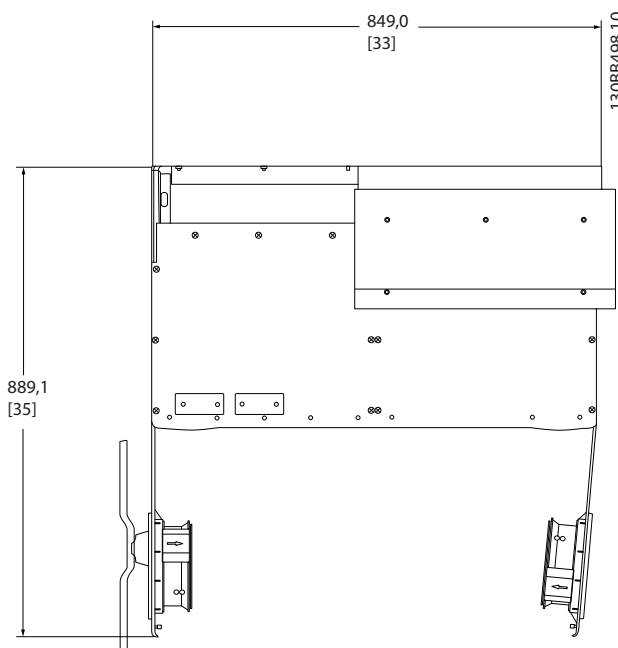

Illustration 4.6: Space in front of IP21/IP54 enclosure type, frame size E.

Wire access

Ensure that proper cable access is present including necessary bending allowance.

NOTE

All cable lugs/ shoes must mount within the width of the terminal bus bar.

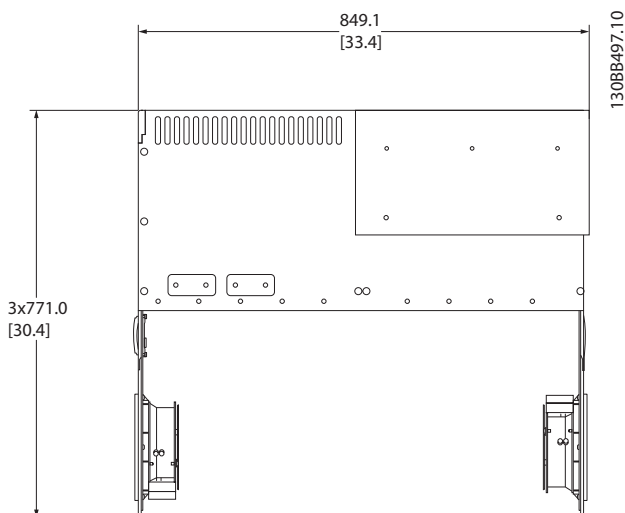

Illustration 4.5: Space in front of IP21/IP54 enclosure type, frame size D.

4.3.3 Terminal Locations - Frame size D

Take the following position of the terminals into consideration when you design for cables access.

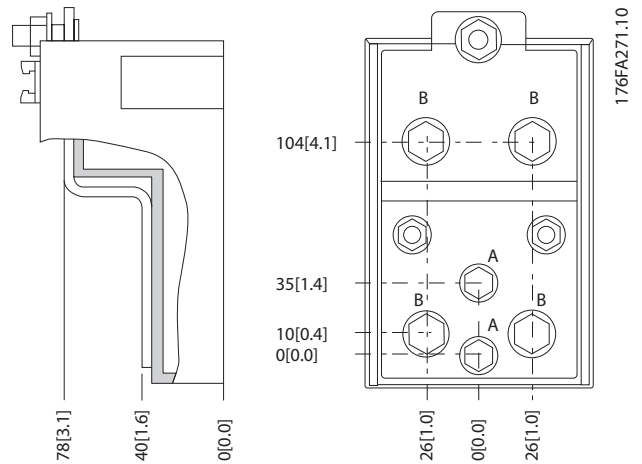
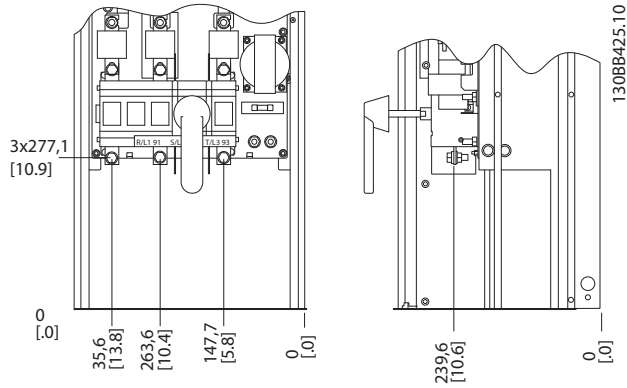

Illustration 4.7: Terminal in details

Be aware that the power cables are heavy and hard to bend. Consider the optimum position of the unit for ensuring easy installation of the cables.

NOTE

All D frames are available with standard input terminals or disconnect switch

4.3.4 Terminal Locations - Frame size E

Take the following position of the terminals into consideration when designing the cable access.

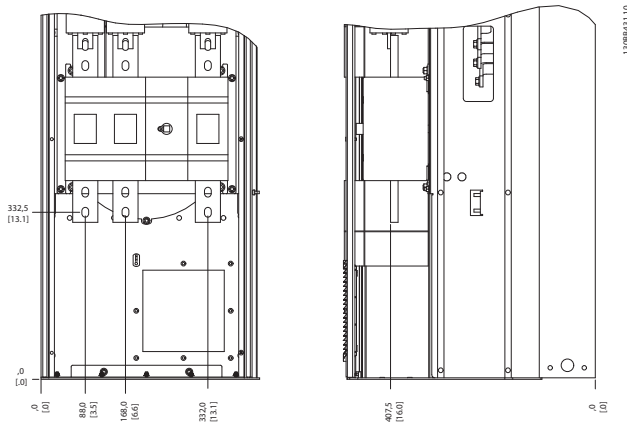

Note that the power cables are heavy and difficult to bend. Consider the optimum position of the unit for ensuring easy installation of the cables.

Each terminal allows use of up to 4 cables with cable lugs or use of standard box lug. Earth is connected to relevant termination point in the unit.

NOTE

Power connections can be made to positions A or B

4.3.5 Cooling and Airflow

Cooling

Cooling can be obtained in different ways, by using the cooling ducts in the bottom and the top of the unit, by taking air in and out the back of the unit or by combining the cooling possibilities.

Back cooling

The backchannel air can also be ventilated in and out the back of a Rittal TS8 enclosure. This offers a solution where the backchannel could take air from outside the facility and return the heat losses outside the facility thus reducing air-conditioning requirements.

NOTE

A door fan(s) is required on the enclosure to remove the heat losses not contained in the backchannel of the unit and any additional losses generated from other components installed inside the enclosure. The total required air flow must be calculated so that the appropriate fans can be selected. Some enclosure manufacturers offer software for performing the calculations (i.e. Rittal Therm software).

Airflow

The necessary airflow over the heat sink must be secured. The flow rate is shown below.

Enclosure protection	Frame size	Door fan(s) / Top fan airflow	Heatsink fan(s)
		Total airflow of multiple fans	Total airflow of multiple fans
IP21 / IP54	D	510 m ³ /h (300 cfm)	2295 m ³ /h (1350 cfm)
	E	680 m ³ /h (400 cfm)	2975 m ³ /h (1750 cfm)

Table 4.1: Heatsink Air Flow

NOTE

For the active filter, the fan runs for the following reasons:

1. Active filter running
2. Active filter not running, but mains current exceeding limit (power size dependent)
3. Specific heatsink temperature exceeded (power size dependent)
4. Specific Power Card ambient temperature exceeded (power size dependent)
5. Specific Control Card ambient temperature exceeded

Once the fan is started it will run for minimum 10 minutes.

External ducts

If additional duct work is added externally to the Rittal cabinet the pressure drop in the ducting must be calculated. Use the charts below to derate the unit according to the pressure drop.

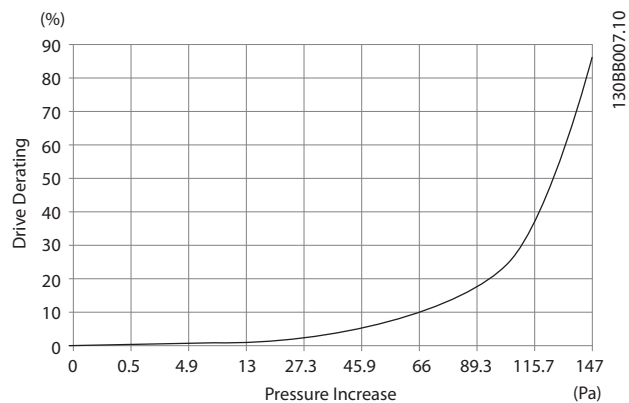

Illustration 4.8: D frame Derating vs. Pressure Change
Air flow: 450 cfm (765 m³/h)

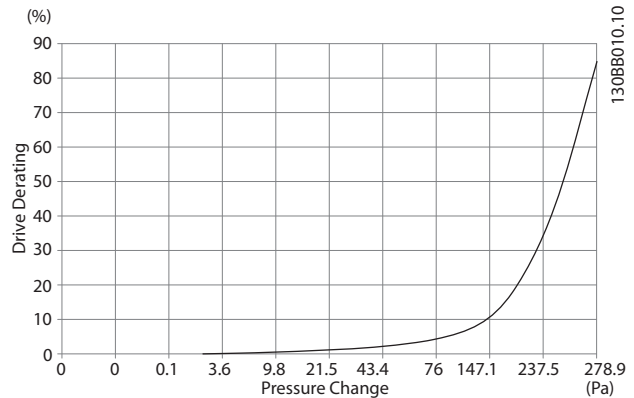

Illustration 4.9: E frame Derating vs. Pressure Change
Air flow: 650 cfm (1105 m³/h)

4.3.6 Gland/Conduit Entry - IP21 (NEMA 1) and IP54 (NEMA12)

Cables are connected through the gland plate from the bottom. Remove the plate and plan where to place the entry for the glands or conduits. Prepare holes in the marked area on the drawing.

4

NOTE

The gland plate must be fitted to the active filter to ensure the specified protection degree, as well as ensuring proper cooling of the unit. If the gland plate is not mounted, the unit may trip on Alarm 69, Pwr. Card Temp

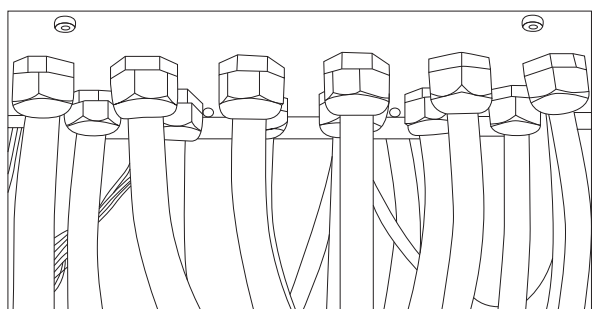
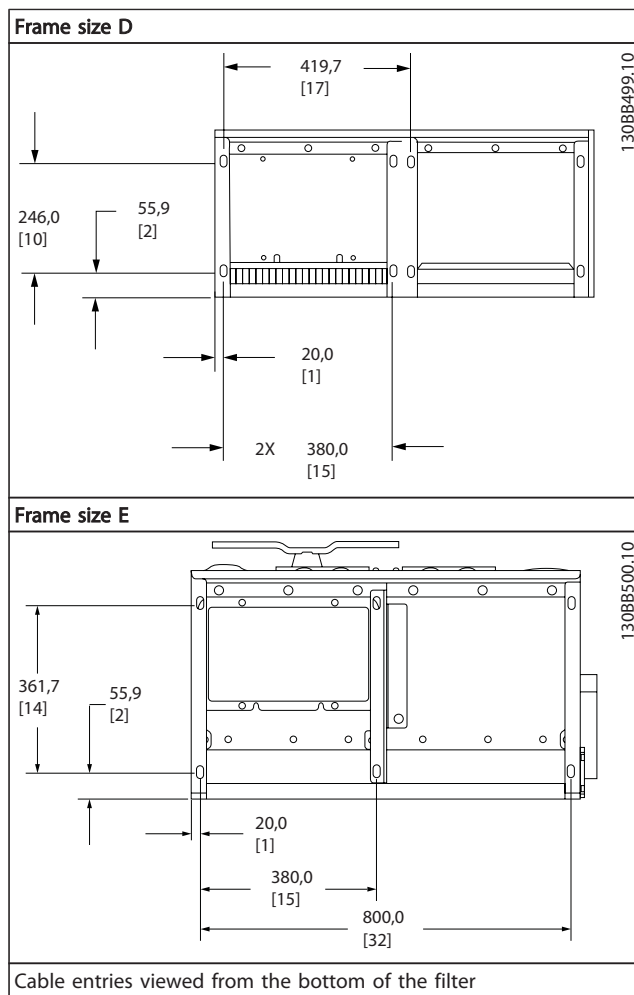

Illustration 4.10: Example of proper installation of the gland plate.



Cable entries viewed from the bottom of the filter

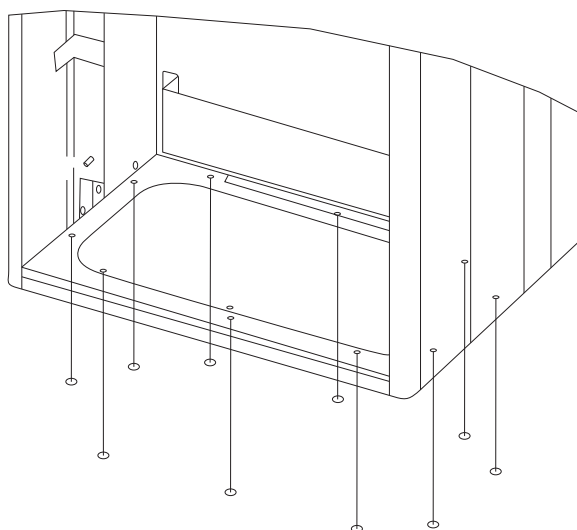
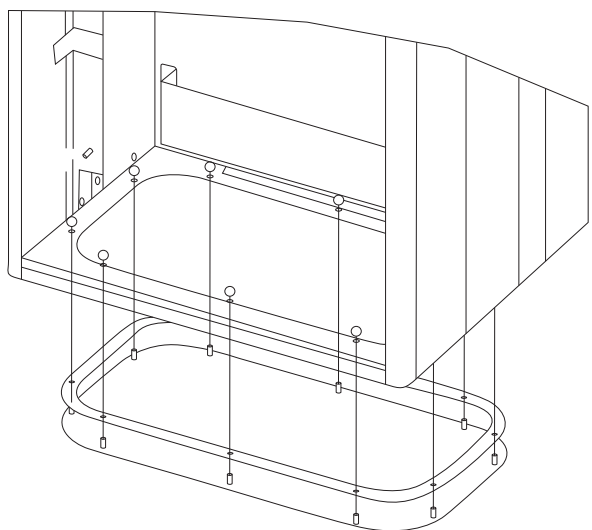

Illustration 4.11: Mounting of bottom plate, E

The bottom plate of the E frame can be mounted from either in- or outside of the enclosure, allowing flexibility in the installation process, i.e. if mounted from the bottom the glands and cables can be mounted before the unit is placed on the pedestal.

4.3.7 IP21 Drip Shield Installation (Frame size D)

To comply with the IP21 rating, a separate drip shield is to be installed as explained below:

- Remove the two front screws
- Insert the drip shield over the filter LCP and replace screws
- Torque the screws to 5,6 Nm (50 in-lbs)

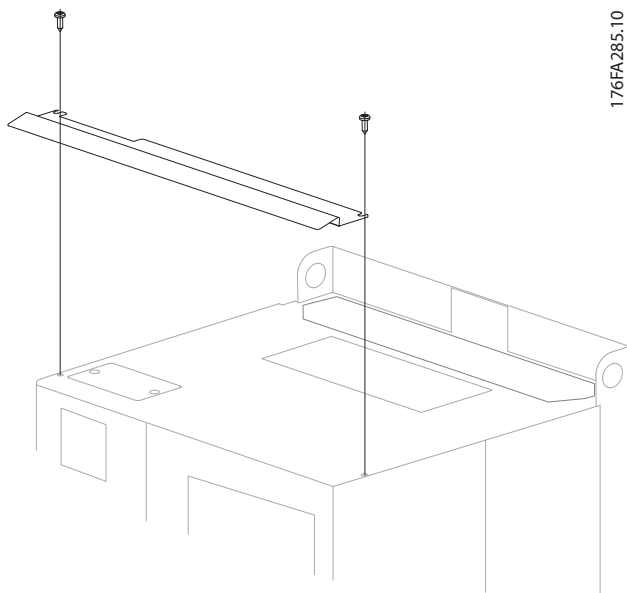

Illustration 4.12: Drip shield installation.

4.4 Field Installation of Options

4.4.1 Installation of Input Plate Options

This section is for the field installation of input option kits available for Active Filters.

Do not attempt to remove RFI filters from input plates.

Damage may occur to RFI filters if they are removed from the input plate.

	Fuses	Disconnect	RFI	Fuses & RFI	Fuses, RFI & Disconnect
D	176Fxxxx	176Fxxxx	176Fxxxx	176Fxxxx	176Fxxxx
E	176Fxxxx	176Fxxxx	176Fxxxx	176Fxxxx	176Fxxxx

NOTE

For further information, please see the Instruction Sheet 175R5795 available for Electrical Drives but also for the Active Filters.

4.4.2 Installation of Mains Shield for Active Filters

The mains shield is for installation with D and E frames and satisfy BG-4 requirements.

Ordering numbers:

D frames: 176Fxxxx

E frames: 176Fxxxx

F frames has mains protection as standard.

NOTE

For further information, please see the Instruction Sheet, 175R5923

F-frame Filters can be supplied with additional options such as cabinet light, power outlet, space heaters, etc. Please contact your local Danfoss representative for these options.

NOTE

Where RFI filters are available, there are two different type of RFI filters depending on the input plate combination and the RFI filters interchangeable.

4.5 Electrical Installation

4.5.1 Current Transformer (CT)

The filter operates in close loop operation by receiving current signals for external current transformers. The received signal is processed and the filter is reacting according to programmed actions. Wrong connection, installed of configuration of the current transformers will lead to improper function of the filter.



Incorrect current transformer connection, installation or configuration will lead to unintended and uncontrollable behaviour of the filter.

NOTE

The current transformers are not part of the filter package and needs to be purchased separately.

Current transformer specification

The Active Filter supports most current transformers. The current transformers have to have the following specifications:

Technical specification of Active filter passive current transformers:	
RMS	maximum measured RMS current
Accuracy	0.5% or better (Class 0.5)
Secondary rated current	1A or 5A (5A is recommended)
Rated frequency	50/60 Hz
Rated apparent power/ burden	See table below (AAF's burden equal 2milliohm)

Rated apparent power/burden [VA]	5	7.5	10	15	30
Impedance of current CT installation [Ω]	≤ 0.15	≤ 0.25	≤ 0.35	≤ 0.55	≤ 1.15

NOTE

All other technical data like dynamic rated current, maximal permitted operating voltage, thermal dimensioning of continuous current, thermal dimensioning of short-time current, over current limit, isolation class, working temperature range etc. are specific values of the system and have to be defined during the project planning phase of the equipment.

The minimum RMS has to be determined by the total current that passes through the current transformer. It is important that the current sensor is not too small leading to saturation of the sensor. Add 10% margin and pick the next following bigger standard RMS rate. It is advised to use current transformers which has a RMS rating close to the maximum current that flows through it to allow the highest possible accuracy of the measurement and so an ideal compensation. In order to ensure that the current transformer performs according to specifications, the rated burden should not be

above the true current requirement by the Active Filter. The burden of the CT is depending on the wire type and the cable length between the CT and the filter CT connection terminal. The filter itself contributes with 2 milliohm.

NOTE

The accuracy of the CT is depending on wire type and length of the cable between filter and current transformer.

The required (minimum) CT burden can be calculated as:
 $[VA] = 25 * [Ohm/M] * [M] + 1,25$
 [Ohm/M] being the cable resistance in Ohm/meter, [M] being the cable length in meters

Below table shows the minimum CT burden for different wire gauge at wire length of 50m and standard wire resistance value:

Wire Gauge [mm2 / AWG]	Resistance [Ohm/Km]	Wire length [meters / feet]	Minimum CT burden [VA]
1,5 / #16	13,3	50 / 164	>16,6
2,5 / #14	8,2	50 / 164	>10,2
4 / #12	5,1	50 / 164	> 6,3
6 / #10	3,4	50 / 164	> 4,2
10 / #8	2	50 / 164	> 2,5

For a fixed CT burden the maximum allowed wire length can be calculated as:
 $[M] = ([VA] - 1,25) / (25 * [Ohm/M])$

Below the maximum wire length of CT with 2,5mm2 wires and resistor value equal 8,2 Ohm/km:

Wire Gauge [mm2 / AWG]	Resistance [Ohm/Km]	Minimum CT burden [VA]	Wire length [meter / feet]
2,5 / #14	8,2	5	<18m / 60
2,5 / #14	8,2	7,5	<30m / 100
2,5 / #14	8,2	10	<42m / 140
2,5 / #14	8,2	15	<67m / 220
2,5 / #14	8,2	30	<140m / 460

Calculation example for correct current transformer for an application with:

RMS= 653Amp, Distance between filter and CT's of 30m.
 RMS=653*1.1= 719A, CT RMS = 750Amp. Burden :
 30m@2,5mm² wire => $25 * 0,0082 * 30 + 1,25 = 7,4$ => 7,5 [VA].

Current transformer installation

The VLT® only supports three CT installation. External CT's should be installed on all three phases to detect the harmonic content of the grid. The flow direction of the sensor is in most cases indicated by an arrow. The arrow should point in the direction of the current flow and so towards the load. In case the flow direction is incorrectly programmed the polarity can be changed via filter parameter 300-25 "CT polarity". Parameter 300-25 can program the polarity of all three phases individually.

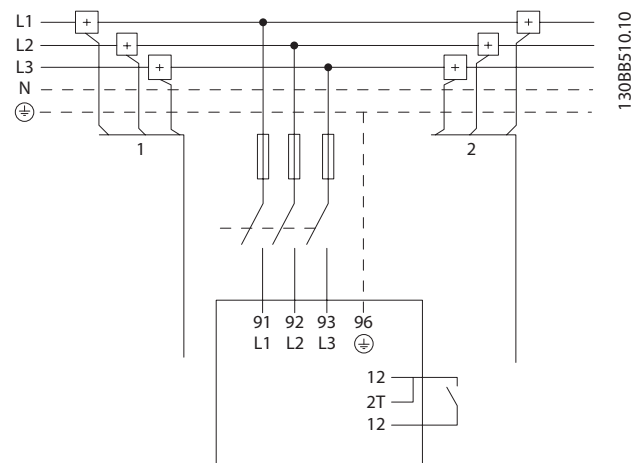

Individual or group compensation

The compensation of the filter is depending on the signal that is returned from the current transformers. The point of installation for these sensors is so determine the loads that are corrected.

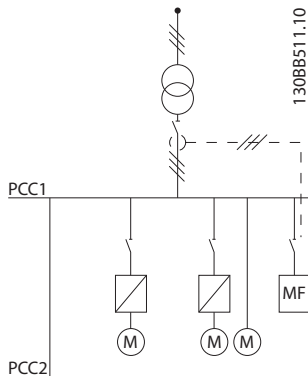

Illustration 4.13: Current transformers installed in front of entire installation and filter is compensating all loads on the transformer.

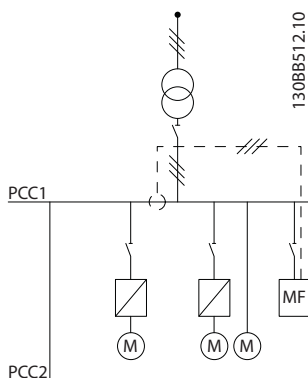

Illustration 4.14: Current transformers are installed in front of distribution bus 2 and one drive and the filter only compensating currents for those.

If the CTs are installed on the secondary side of the transformer and so in front of the entire loads the filter will compensate all loads simultaneous. If above right side example where the CT's are installed in front of only some of the loads the filter will not compensate unwanted current deformation of the drive and motor on the right hand side. If CT's are installed in-front of a single load the filter will only compensate the one load and so form individual load compensation.

The filter can be programmed to have CT's installed on source side also called point of common coupling –side (PCC) or alternatively at the load side. Kirchhoffs first law applies for the connection point and so the sum of currents to the connection point equals zero. The third current is so a function of the two other signed current signals.

NOTE

The filter will as standard be programmed to PCC side installation

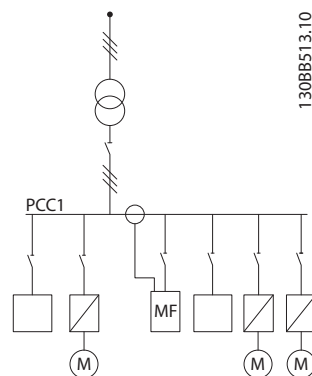

Illustration 4.15: Current transformers installed on source (PCC) side for group compensation.

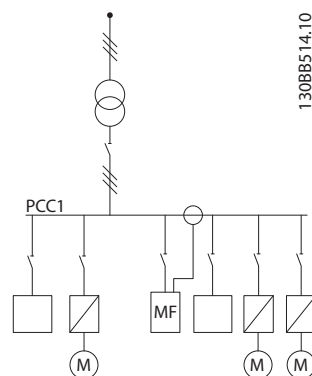

Illustration 4.16: Current transformers installed on load side for group compensation.

If the current transformers are installed on the source (PCC) side the filter will expect a sinusoidal (corrected) signal feedback from the three sensors. In case the sensors are installed on the load side the received signal will be subtracted from the ideal sine wave to calculate the needed corrected current.

NOTE

Erratic filter operation is a result of incorrect current transformers connection point programming

Multiple current sources:

In case the filter is to compensate current from several sources it is needed to install summation CT's. This is often the case if filter is installed in systems with generator back-up or where the filter is only to compensate a limited number of loads.

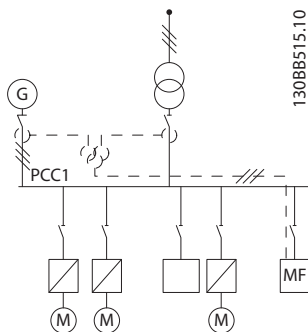

Illustration 4.17: Summation CT's on generator backup applications (PCC-side). Filter compensates full current of transformer and generator.

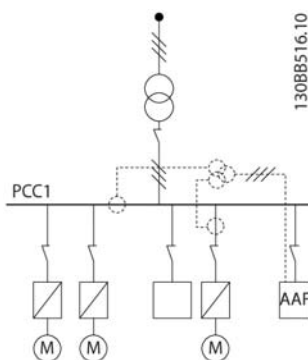

Illustration 4.18: Summation CT's example for individual harmonic compensation (load side).

Summation current transformers are available with multiple (2-5) inputs and common output. For application where summations CT's are used to add current from several sources make sure that all CT's connected to the summation are from the same fabricate and that the CT have:

- same polarity
- same primary rate
- same RMS value
- same accuracy (class 0,5)
- same location (PCC or load-side)
- same phase sequence

NOTE

Use summation CT with great caution and always unsure correct phase sequence, current direction, primary and secondary rate. If installation is incorrect the filter will not work according to expectations.

The current transformers burden calculation has to include all wires in the installation and must be conducted for the longest total wire string when using summation CT's.

Active filter operating with capacitor banks

The VLT active filter is able to run in conjunction with capacitor banks as long as the resonance frequency of the capacitor bank is not in the operation range of the Active filter.

NOTE

Always use detuned capacitor banks in installation with variable speed drives and active filters to avoid resonance phenomena's, unintended tripping or even brake down.

For the case of detuned capacitors, the resonance frequency capacitors should be tuned for an inter-harmonic number lower then the 5th harmonic. The VLT active filter has to operate in selective compensation mode if filter is installed in conjunction with capacitor banks of any kind. Capacitor bank should ideally be installed upstream of the filter / towards the transformer. If not possible the current transformers should be installed in a way that they do not measure both needed current compensation and the capacitor corrected current.

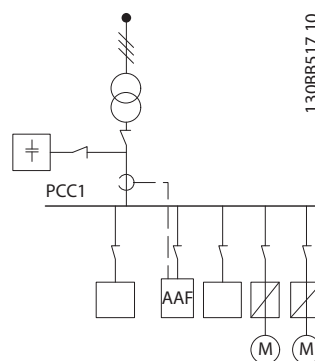

Illustration 4.19: Capacitor bank mounted up stream and CT's installation does not measure capacitor current.

Below diagram shows recommended installation of the active filter and CT placement in installations holding capacitor banks:

For installation where the CT's connection point can be moved below connections is also OK. For some few retrofit applications summation CT are needed to reassure that the capacitor current is not measured.

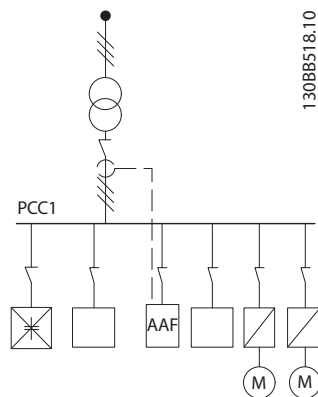

Illustration 4.20: Not allowed installation. Corrected capacitor current interacts with CT measurement.

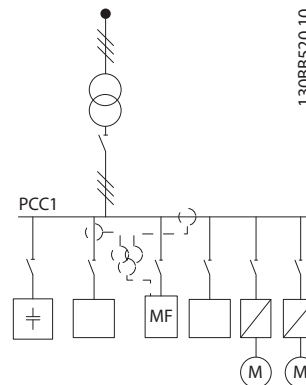

Illustration 4.22: Capacitor bank mounted on PCC but CT's installed to reassure that capacitor corrected current is not measured.

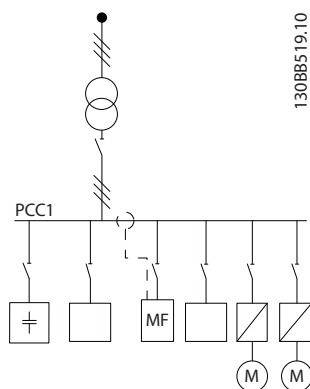

Illustration 4.21: CT's installation does not measure capacitor current.

Auto CT detection

The VLT Active Filter is able to perform an auto detection of the installed CT. The ct auto detection can be conducted both while the system is running and at no load conditions. The filter injects a prefixed current of known amplitude and phase angle and is measuring the returned CT input. The performance is conducted on each phase individually and for several frequencies to reassure phase sequence and that harmonics of different correctly.

The Auto CT detection is pending on the follow conditions:

- Active filter bigger then 10% of CT RMS rate
- CT's installed on source (PCC) side (auto CT not possible for load side CT installation)
- Only one CT per phase (not possible for summation CT's)
- CT's are part of below standard range:

Sec 1 A	150	200	250	300	400	500	600	750	1000	1250	1500	2000	2500	3000	3500	4000
Sec 5 A	30	40	50	60	80	100	120	150	200	250	300	400	500	600	700	800

4.5.2 Power Connections

Cabling and fusing

NOTE

Cables General

All cabling must comply with national and local regulations on cable cross-sections and ambient temperature. UL applications require 75 °C copper conductors. 75 and 90 °C copper conductors are thermally acceptable to use in non UL applications.

The power cable connections are situated as shown below. The mains connection is fitted to the mains switch if this is included. Dimensioning of cable cross section must be done in accordance with the filter current rating including skin and proximity effects, derating and local legislation. Please see the section "Mains Connection" for more details.

NOTE

If is insufficient to rate the power cable for the filter current rating alone due to skin and proximity effects.

For protection of the active filter, the recommended fuses must be used or the unit must be with built-in fuses. Recommended fuses can be seen in the tables of the fuse section. Always ensure that proper fusing is made according to local regulation.

The mains connection is fitted to the mains switch if this is included.

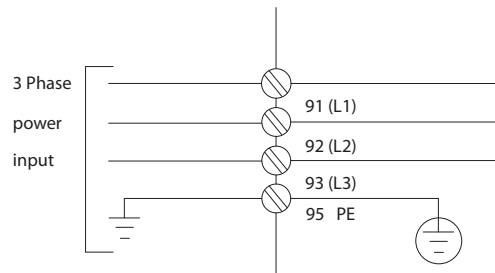

130BA026.10

Screening of cables:

Avoid installation with twisted screen ends (pigtailed). They spoil the screening effect at higher frequencies.

Make the screen connections with the largest possible surface area (cable clamp). This is done by using the supplied installation devices within the unit.

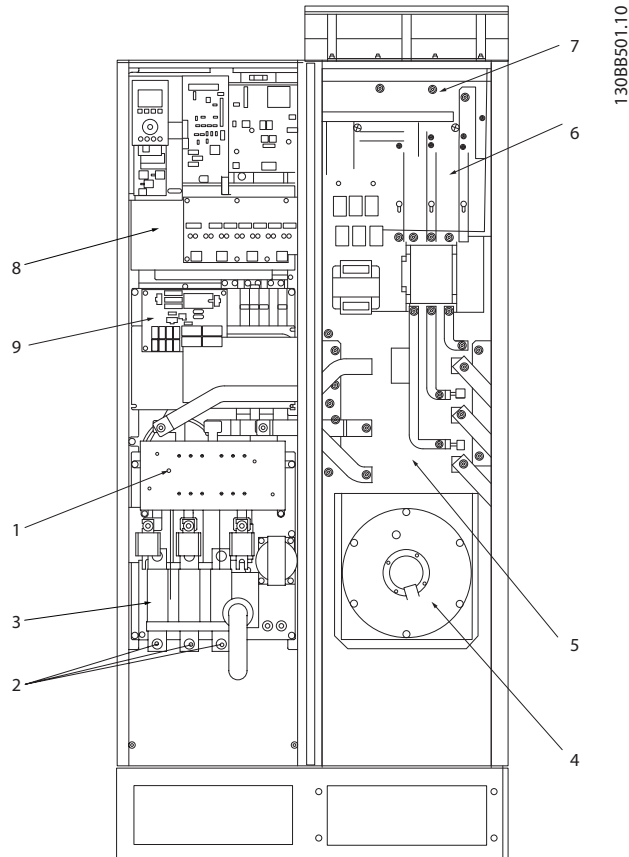

130BB501.10

Illustration 4.23: Frame size D

1) RFI	5) LCL line reactor
2) Line R S T L1 L2 L3	6) LCL capacitors
3) Input plate	7) LCL filter reactor
4) Backchannel fan	8) CT-wire connection point
	9) Fan/ SMPS fuse

4

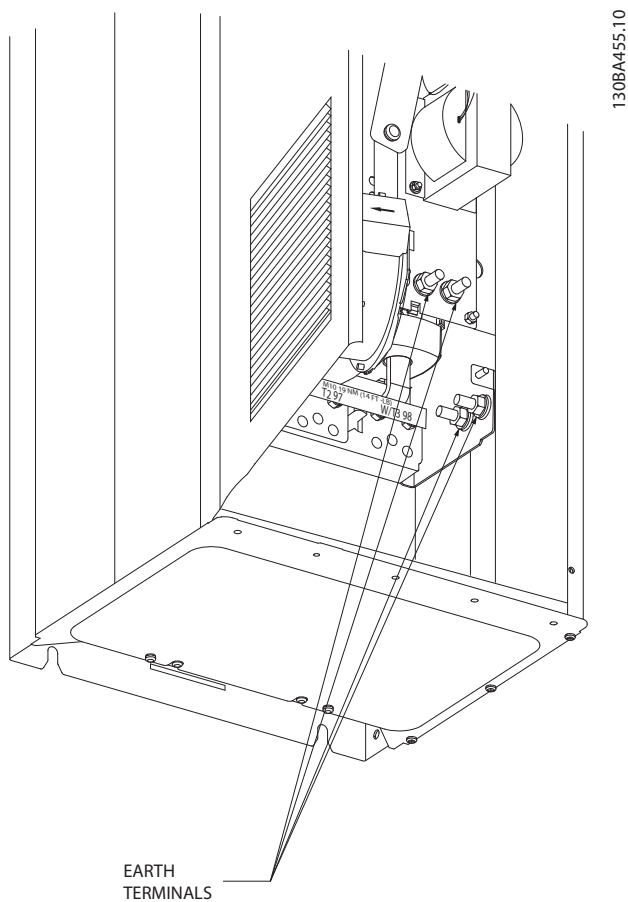

Illustration 4.24: Position of earth terminals

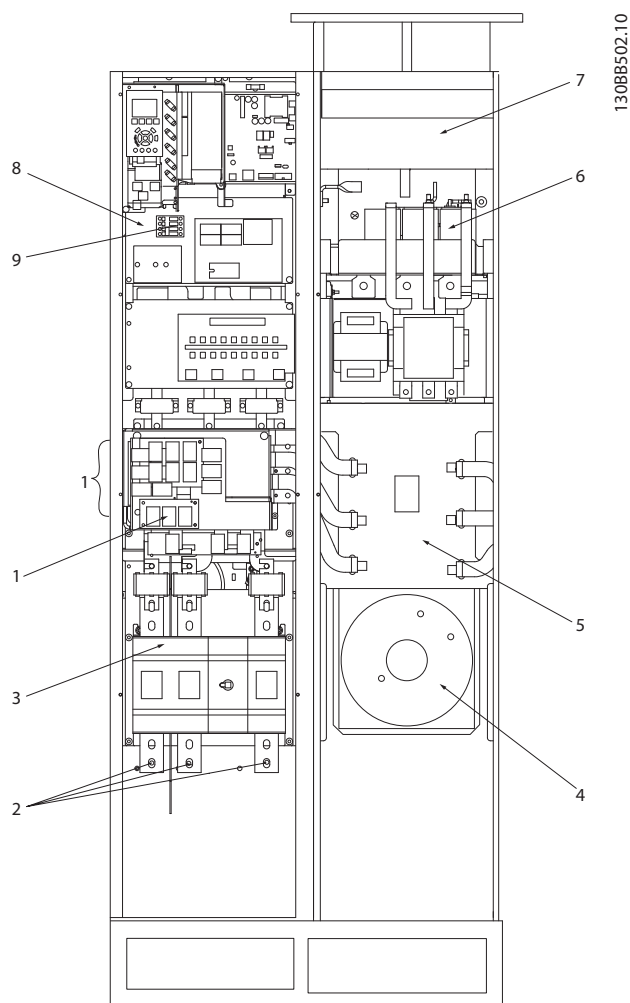

Illustration 4.25: Frame size E

1)	RFI	5)	LCL line reactor
2)	Line	6)	LCL capacitors
	R S T	7)	LCL filter reactor
	L1 L2 L3	8)	CT-wire connection point
3)	Input plate	9)	Fan/ SMPS fuse
4)	Backchannel fan		

4.5.3 Earthing

The following basic issues need to be considered when installing an active filter, so as to obtain electromagnetic compatibility (EMC).

- Safety earthing: Please note that the active filter has a high leakage current and must be earthed appropriately for safety reasons. Apply local safety regulations.
- High-frequency earthing: Keep the earth wire connections as short as possible.

Connect the different earth systems at the lowest possible conductor impedance. The lowest possible conductor

4.5.4 Extra Protection (RCD)

ELCB relays, multiple protective earthing or earthing can be used as extra protection, provided that local safety regulations are complied with. In the case of an earth fault, a DC component may develop in the fault current. If ELCB relays are used, local regulations must be observed. Relays must be suitable for protection of 3-phase equipment with a bridge rectifier and for a brief discharge on power-up.

4.5.5 RFI Switch

Mains supply isolated from earth

If the Active filter is supplied from an isolated mains source (IT mains, floating delta and grounded delta) or TT/TN-S mains with grounded leg, the RFI switch is recommended to be turned off (OFF) 1) via par. 14-50 RFI Filter on the unit. For further reference, see IEC 364-3. In OFF, the internal RFI capacities between the chassis and the intermediate circuit are cut off to avoid damage to the intermediate circuit and to reduce the earth capacity currents (according to IEC 61800-3). Please also refer to the application note VLT on IT mains, MN.90.CX.02. It is important to use isolation monitors that are capable for use together with power electronics (IEC 61557-8).

4.5.6 Torque

When tightening all electrical connections it is very important to tighten with the correct torque. Too low or too high torque results in a bad electrical connection. Use a torque wrench to ensure correct torque. Below is the tightening torque required for the mains terminal:

Frame size	Torque	Bolt size
D	19-40Nm	M10
E	19-40Nm	M10

impedance is obtained by keeping the conductor as short as possible and by using the greatest possible surface area. The metal cabinets of the different devices are mounted on the cabinet rear plate using the lowest possible HF impedance. This avoids having different HF voltages for the individual devices and avoids the risk of radio interference currents running in connection cables that may be used between the devices. The radio interference will have been reduced. In order to obtain a low HF impedance, use the fastening bolts of the devices as HF connection to the rear plate. It is necessary to remove insulating paint or similar from the fastening points.

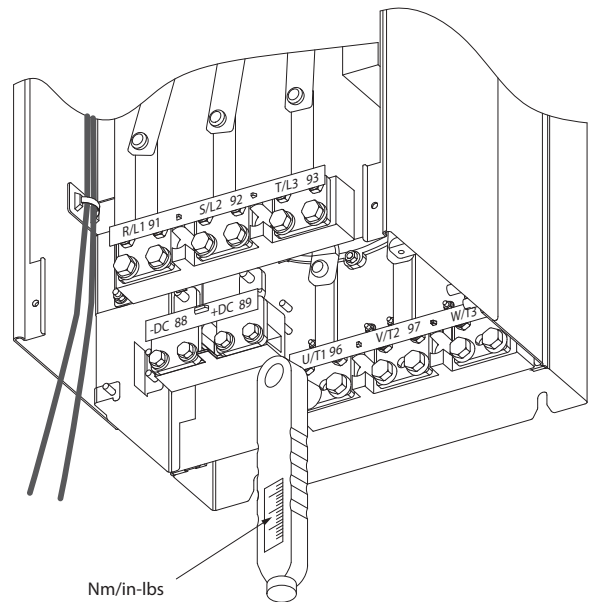

Illustration 4.26: Always use a torque wrench to tighten the bolts.

4.5.7 Shielded Cables

It is important that shielded and armoured cables are connected in a proper way to ensure high EMC immunity and low emissions.

Connection can be made using either cable glands or clamps:

- EMC cable glands: Generally available cable glands can be used to ensure an optimum EMC connection.
- EMC cable clamp: Clamps allowing easy connection are supplied with the unit.

4.5.8 Mains Connection

Mains must be connected to terminals 91, 92 and 93 located on the far left of the unit. Earth is connected to the terminal to the right of terminal 93.

Terminal No.	Function
91, 92, 93	Mains R/L1, S/L2, T/L3
94	Earth

The conductor is predominantly carrying currents of high frequencies so the distribution of current is not evenly dispersed throughout the cross section of the conductor. This is due to two independent effects known as skin effect and proximity effect. Both effects make derating necessary and consequently the mains wire of the Active Filters have to be rated at a higher current than the filter rating itself.

NOTE

If is insufficient to rate the power cable for the filter current rating alone due to skin and proximity effects.

Filter	Min CU wire	Min ALU wire	Max wire
190A	70mm ² (2/0)	95mm ² (3/0)	2*150mm ² (2*300MCM)
250A	120mm ² (4/0)	150mm ² (300MCM)	4x240mm ² (4x500MCM)
310A	240 mm ² (500MCM)	2*95mm ² (2*3/0)	4x240mm ² (4x500MCM)
400A	2*95mm ² (2*3/0)	2*150mm ² (2*300MCM)	8x450mm ² (8x900MCM)
500A	2*240mm ² (2*500MCM)	2*300mm ² (2*600MCM)	8x450mm ² (8x900MCM)

Table 4.2: Allowed active filter mains cable with typical cable manufacturer data

Due to the built-in LCL filter the unit will not feed the main wire with high du/dt signals but only conduct a limited amount of high order harmonics. That reduces the radiated emission through the power cable. Cable screen/shielding can thus be omitted allowing the mains cables to be connected without considering EMC requirements.

The Active Filter will be able to run at long cable runs. Cable length is limited by the voltage drop. It is advised to keep the cable lengths to less than 200m.

4.5.9 External Fan Supply

In case the Active filter is supplied by DC or if the fan must run independently of the power supply, an external power supply can be applied.

Terminal No.	Function
100, 101	Auxiliary supply S, T
102, 103	Internal supply S, T

The connector located on the power card provides the connection of line voltage for the cooling fans. The fans are connected from factory to be supplied from a common AC line (jumpers between 100-102 and 101-103). If external supply is

The required derating is calculated as two separate factors: one for the skin effect and one for the proximity effect. The skin factor is depending on frequency of conduct, cable material and cable dimensions. The proximity effect is depending on the number of conducts, diameters and distance between the individual cables.

The optimized mains wire is:

- Copper wires
- Single conducts
- Busbars

The reason for that is that copper has lower skin effect factors than aluminium, busbars have bigger surface area compared to cables reducing the skin effect factor and proximity effects of single conducts is negligible.

The following cables specifications take both skin and proximity effects into account:

needed, the jumpers are removed and the supply is connected to terminals 100 and 101. A 5 Amp fuse should be used for protection. In UL applications this should be LittleFuse KLK-5 or equivalent.

4.5.10 Power and Control Wiring for Unscreened Cables



Induced Voltage!

Run input power and control wiring in separate metallic conduits or raceways for high frequency noise isolation. Failure to isolate power and control wiring could result in less than optimum controller and associated equipment performance.

Control wiring including CT-wires should always be isolated from the high voltage power wiring. When screened/ armoured cable is not used, at least separate conduits must be connected to the panel option for the power wiring and the control wiring.

4.5.11 Fuses

Branch circuit protection:

In order to protect the installation against electrical and fire hazard, all branch circuits in an installation, switch gear, machines etc., must be short-circuited and over-current protected according to national/international regulations.

Short-circuit protection:

The Active Filter must be protected against short-circuit to avoid electrical or fire hazard. Danfoss recommends using the fuses mentioned below to protect service personnel and equipment in case of an internal failure in the device.

Over-current protection

The active filter is equipped with an internal over-current protection that avoids overload in normal running conditions. Provide overload protection is however needed in case of

internal failures to avoid fire hazard due to overheating of the cables in the installation. Fuses or circuit breakers can be used to provide the needed protection for the installation. Over-current protection must always be carried out according to national regulations.

Non UL compliance

If UL/cUL is not to be complied with, we recommend using the following fuses, which will ensure compliance with EN50178:

Unit	Voltage	Fuse type
190A	T4	gG
250-310A	T4	gR

Supplementary fuses

Frame size	Bussmann PN*	Rating
D and E	KTK-4	4 A, 600 V

Table 4.3: SMPS Fuse

Size/Type	Bussmann PN*	Littelfuse	Rating
A190-250A, 380-480 V	KTK-4		4 A, 600 V
A310A, 380-480 V		KLK-15	15A, 600 V

Table 4.4: Fan Fuses

4.5.12 Mains Disconnectors - Frame Size D and E

Frame size	Power & Voltage	Type
D	A190 380-480V	OT400U12-91
E	A250 380-480V	ABB OETL-NF600A
E	A310 380-480V	ABB OETL-NF800A

4.5.13 Control and CT Cable Routing

Tie down all control wires to the designated control cable routing as shown in the picture. Remember to connect the shields in a proper way to ensure optimum electrical immunity.

CT connection

Connections are made to the terminal block below the active filter card. The cable must be placed in the provided path inside the filter and tied down together with other control wires (see pictures).

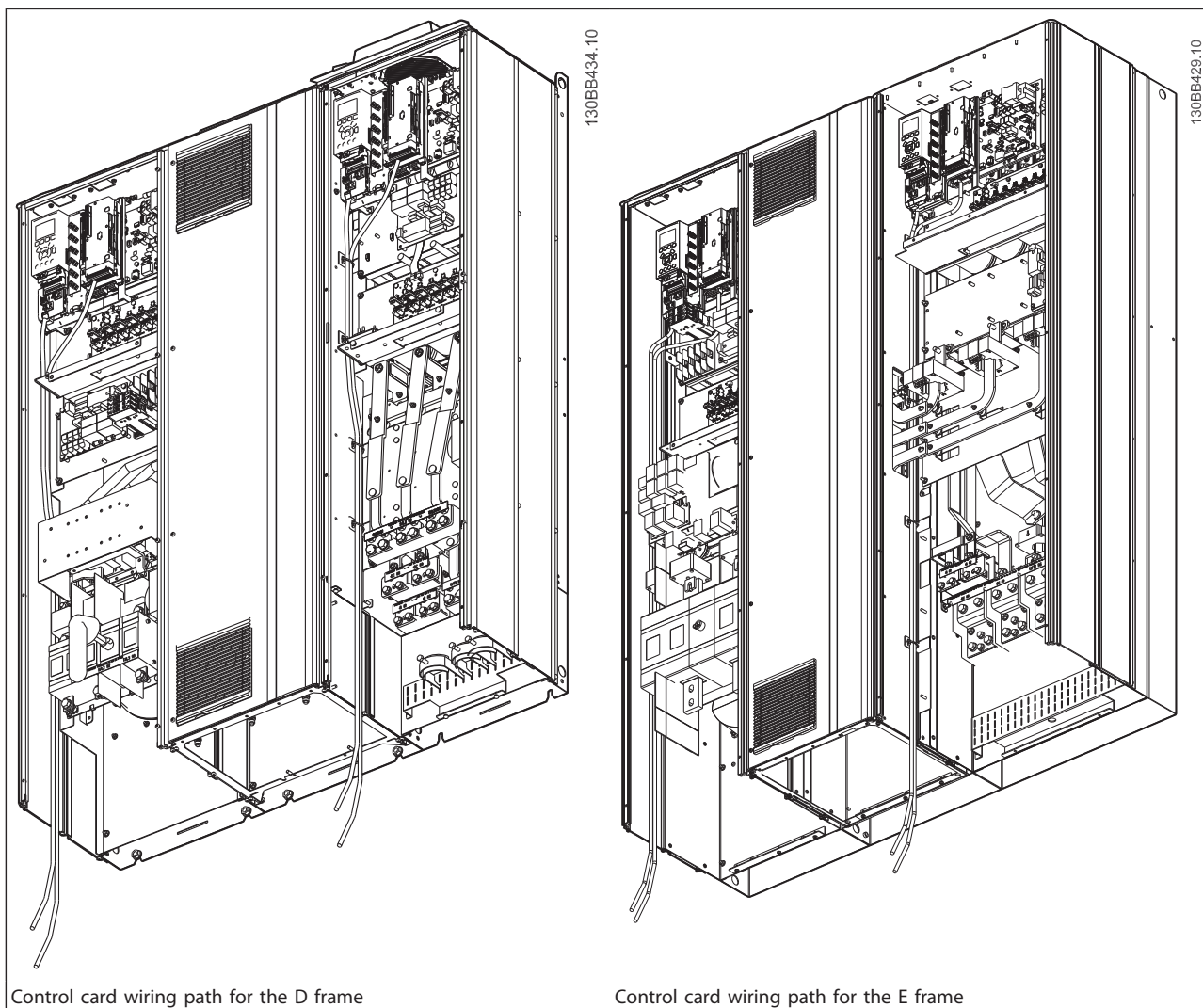

Control card wiring path for the D frame

Control card wiring path for the E frame

4.5.14 Access to Control Terminals

All terminals to the control cables are located beneath the LCP. They are accessed by opening the door of the unit.

4.5.15 Electrical Installation, Control Terminals

To connect the cable to the terminal:

1. Strip insulation by about 9-10 mm
2. Insert a screwdriver¹⁾ in the square hole.
3. Insert the cable in the adjacent circular hole.
4. Remove the screwdriver. The cable is now mounted in the terminal.

To remove the cable from the terminal:

1. Insert a screw driver¹⁾ in the square hole.
 2. Pull out the cable.
- ¹⁾ Max. 0.4 x 2.5 mm

4

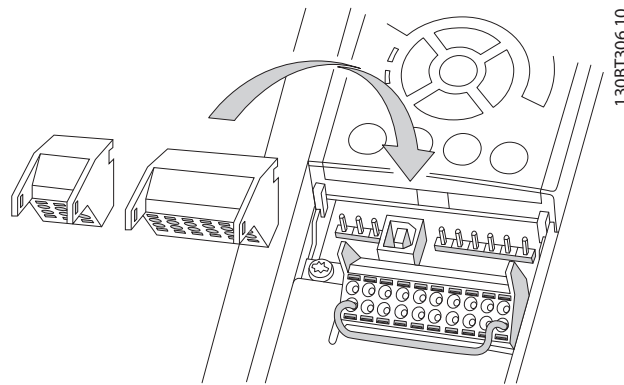
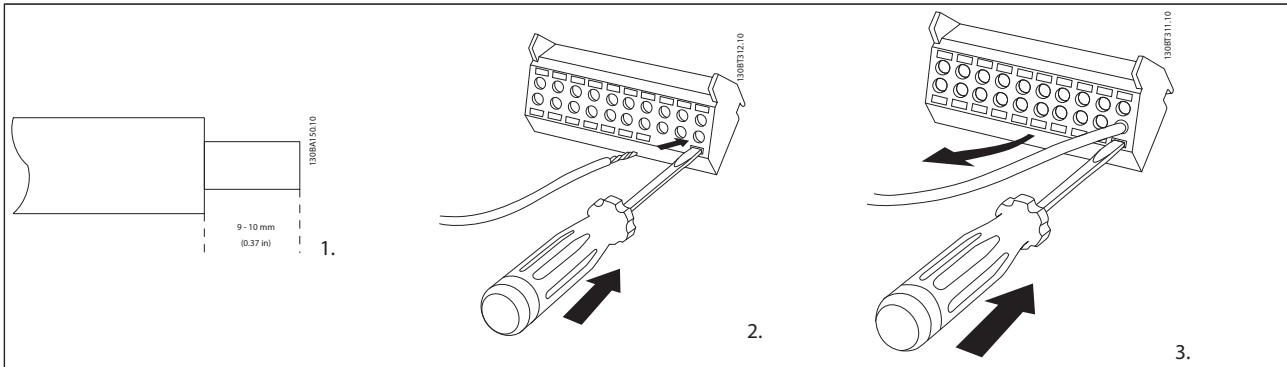

4.6.1 Electrical Installation, Control Cables

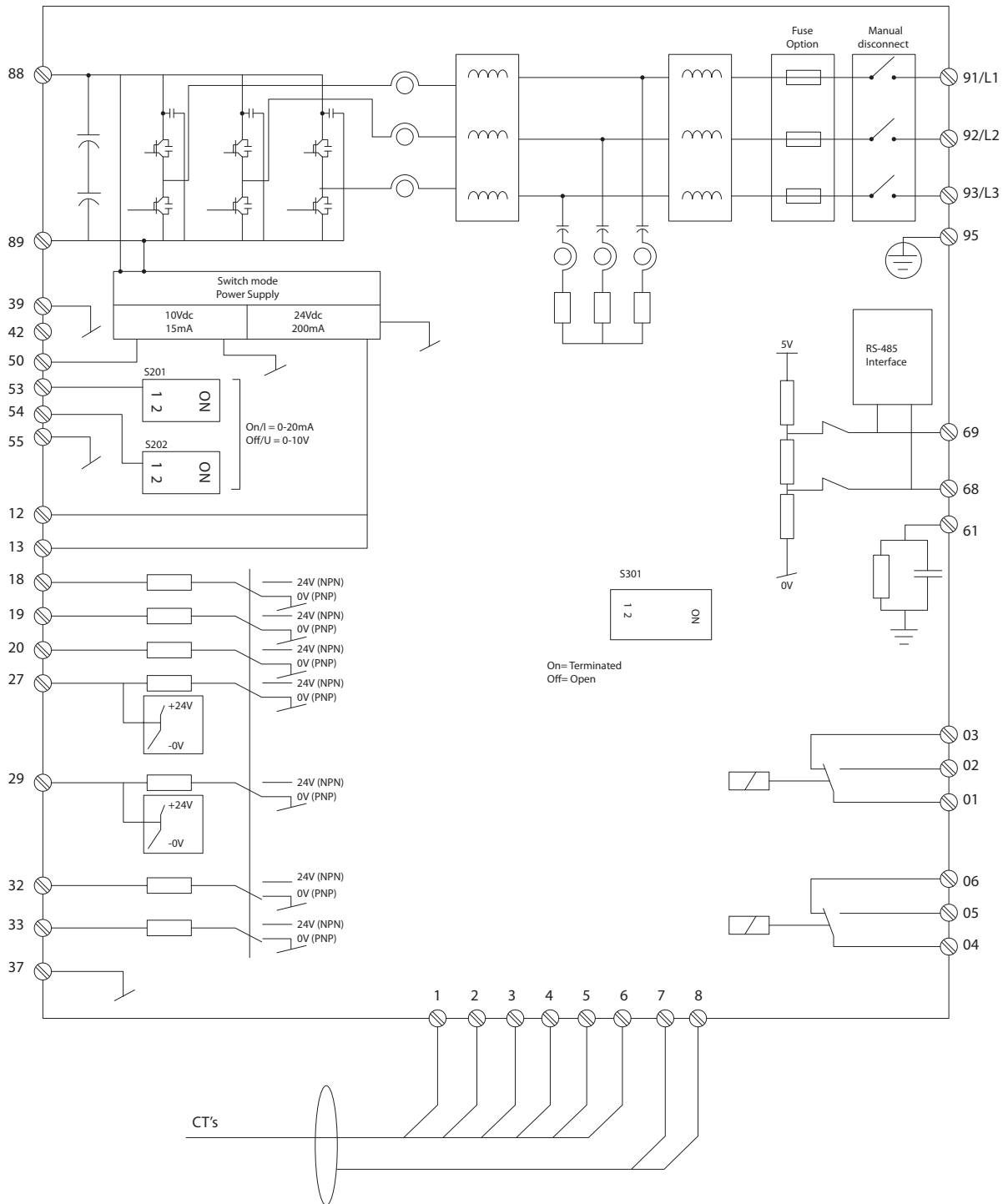

130BB507.10

Illustration 4.27: Diagram showing all electrical terminals without options.

Terminals L1, L2 and L3 (91,92,93 and 95) are grid connection terminals Terminal 37 is the input to be used for Safe Stop. See also sections Safe Stop and Safe Stop Installation. Gray scaled terminals are already used for internal operation or are not configurable via software of the Active Filter.

NOTE

Terminals are not all located on the same PCB.

Very long control cables and analogue signals may in rare cases and depending on installation result in 50/60 Hz earth loops due to noise from mains supply cables.

If this occurs, it may be necessary to break the screen or insert a 100 nF capacitor between screen and chassis.

Input polarity of control terminals

4

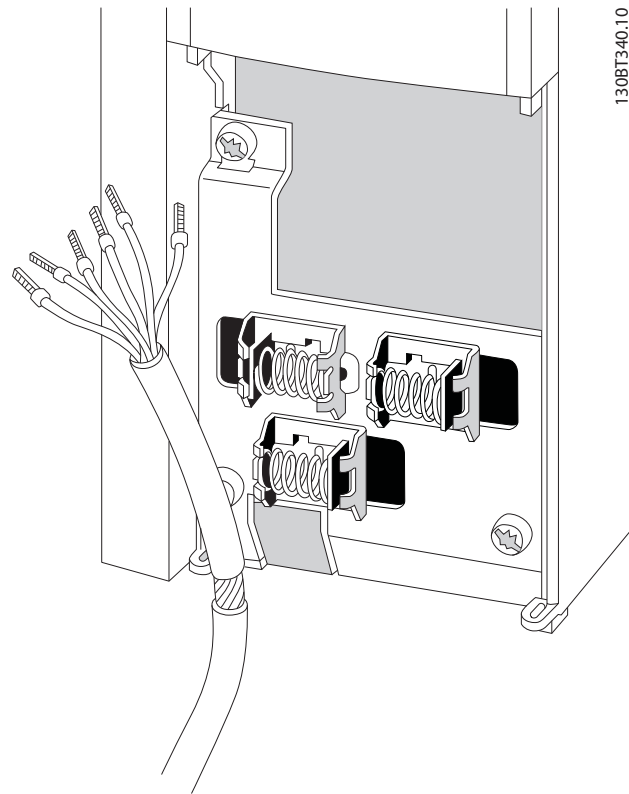
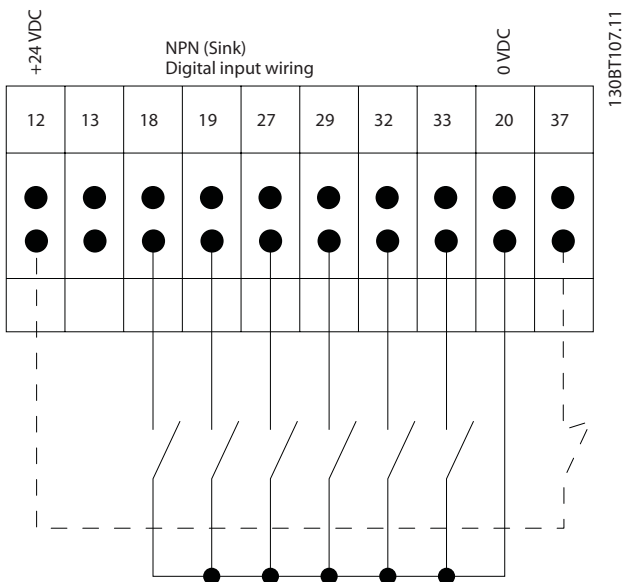
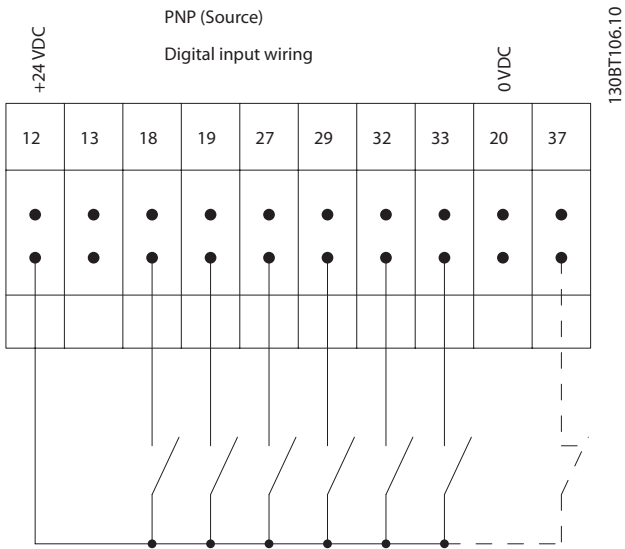

Remember to connect the shields in a proper way to ensure optimum electrical immunity.

NOTE

To comply with EMC emission specifications, screened/ armoured cables are recommended. If an unscreened/ unarmoured cable is used, see section *Power and Control Wiring for Unscreened Cables*. If unscreened control cables are used, it is recommended to use ferrite cores to improve EMC performance.

4.6 Final Set-Up and Test

External CT setting are programmed via parameter group 300-2*. It is advised to perform an automatic CT-detection for all standalone filters via parameter 300-29.

CT secondary side rating need to be set before an automatic CT-detection is performed. Filter support all standard CTs with 1A or 5A secondary rating. CT secondary rating is configured in parameter 300-21.

To test the set-up and ensure that the Active Filter is running correctly, follow these steps:

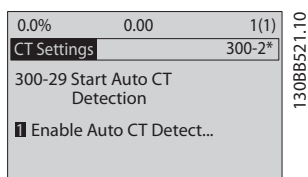

CT's should have an accuracy of 0.5% or better to reassure sufficient accuracy.

NOTE

Do not perform this for the LHD

NOTE

The automatic CT-detection is only possible with CT installed on the load side

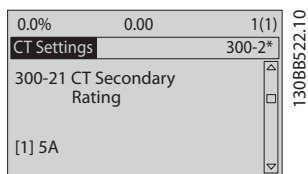

Follow these steps to reassure correct installed current transformers:



Incorrect current transformer connection, installation or configuration will lead to unintended and uncontrollable behaviour of the filter.

1.	Par. 300-10 AAF Nominal voltage
2.	Par. 300-26 CT Placement
3.	Par. 300-21 CT Secondary Rating
4.	Par. 300-29 Start Auto CT Detection



Step 1: Enter the filter nominal voltage in parameter 300-10.

Step 2: Locate the CT and note the position in the installation and the secondary current level.

Step 3: Enter the CT-location in parameter 300-26 and the secondary current from the plate data in this parameter 300-21.

Step 4: Enter the CT-location in parameter 300-26 and the secondary current from the plate data in this parameter 300-21.

Performing an Auto CT:

The automatic current transformer detection will set the CT polarity, phase sequence and current ratio.

Stop the CT detection during operation:

Press the [off] key – the filter enters into alarm mode and display show that the Auto CT was terminated by the user.

Successful CT detection:

The display will show the found ratios, parameters, and the phase sequence. Press [OK] to accept the found parameters. After the CT detection the filter is ready to start operation.

CT detection failed:

Danfoss CT auto detection support most standard CTs. The auto CT detection will not succeed if:

- CT's are not wired correctly
- CT's are installed on load side
- Primary rate is not a standard size
- Secondary rate and CT placement is not configured
- CT current primary rate is bigger then 10 times filter current rate

A manual configuration is needed in case the automatic CT detection fails to set the CT's. In that case set the following parameters according to the CT plate data and installation:

1. 300-20 CT Primary Rating
2. 300-24 phase sequence
3. 300-25 CT polarity

The active filter allows different CT polarity of all three current transformers. That means that parameter 300-25 "CT polarity" need to be set for all three CT's individually.

Then the current transducers are successful configured the filter is ready to start it operation. To setup the filter compensation mode and priority please consult the chapter **How to programme**.

5 How to Operate the Active Filter

The display is divided into 3 sections:

Top section (a)

shows the status when in status mode or up to 2 variables when not in status mode and in the case of Alarm/Warning.

5.1 Ways of Operation

The Active Filter can be operated in 2 ways:

1. Graphical Local Control Panel (GLCP)
2. RS-485 serial communication or USB, both for PC connection

5.1.1 How to Operate Graphical LCP (GLCP)

The GLCP is divided into four functional groups:

1. Graphical display with Status lines.
2. Menu keys and indicator lights (LED's) - selecting mode, changing parameters and switching between display functions.
3. Navigation keys and indicator lights (LEDs).
4. Operation keys and indicator lights (LEDs).

Graphical display:

The LCD-display is back-lit with a total of 6 alpha-numeric lines. All data is displayed on the LCP which can show up to five operating variables while in [Status] mode.

Display lines:

- a. **Status line:** Status messages displaying icons and graphics.
- b. **Line 1-2:** Operator data lines displaying data and variables defined or chosen by the user. By pressing the [Status] key, up to one extra line can be added.
- c. **Status line:** Status messages displaying text.

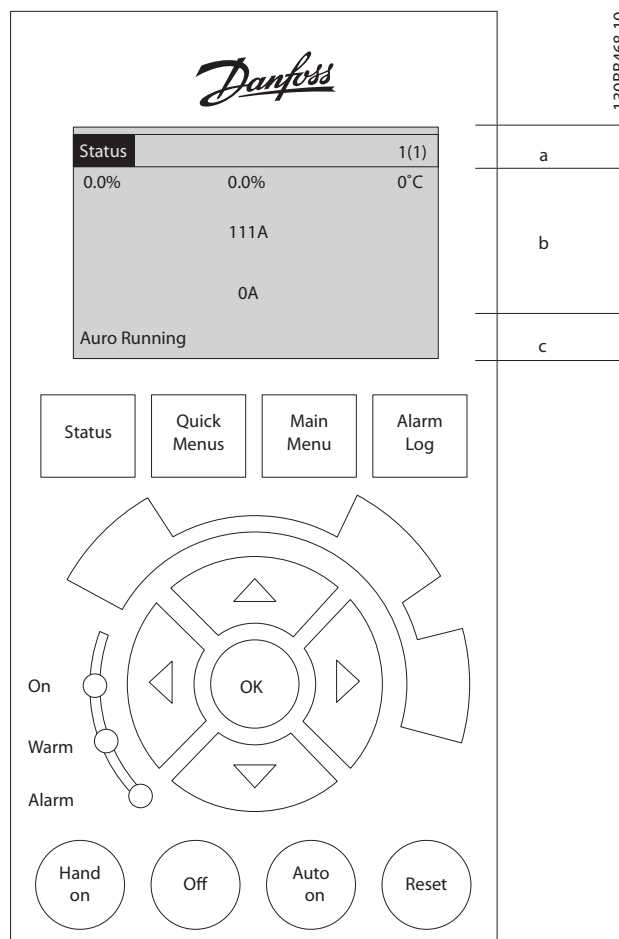

The number of the Active Set-up (selected as the Active Set-up in par. 0-10) is shown. When programming in another Set-up than the Active Set-up, the number of the Set-up being programmed appears to the right in brackets.

Middle section (b)

shows up to 5 variables with related unit, regardless of status. In case of alarm/warning, the warning is shown instead of the variables.

It is possible to toggle between three status read-out displays by pressing the [Status] key.

Operating variables with different formatting are shown in each status screen - see below.

Several values or measurements can be linked to each of the displayed operating variables. The values / measurements to be displayed can be defined via par. 0-20, 0-21, 0-22, 0-23, and 0-24, which can be accessed via [QUICK MENU], "Q3 Function Setups", "Q3-1 General Settings", "Q3-11 Display Settings".

Each value / measurement readout parameter selected in par. 0-20 to par. 0-24 has its own scale and number of digits after a possible decimal point. Larger numeric values are displayed with few digits after the decimal point.

Ex.: Current readout
5.25 A; 15.2 A 105 A.

Status display I

This read-out state is standard after start-up or initialization. Use [INFO] to obtain information about the value/measurement linked to the displayed operating variables (1.1, 1.2, 1.3, 2, and 3).

See the operating variables shown in the display in this illustration. 1.1, 1.2 and 1.3 are shown in small size. 2 and 3 are shown in medium size.

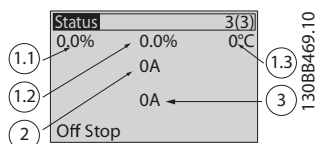

Status display II

See the operating variables (1.1, 1.2, 1.3, and 2) shown in the display in this illustration.

In this example the small readout are: Power Factor in the upper left corner (position 1.1). THiD of Current in the middle top (position 1.2), The mains current is displayed in the upper right corner (1.3). Large readouts are the Output current (position 2) and lastly underneath the mains frequency is the reactive current at position 3.

1.1, 1.2 and 1.3 are shown in small size. 2 is shown in large size.

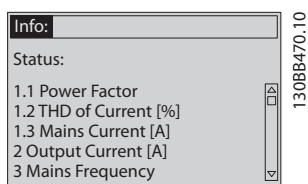

Bottom section

always shows the state of the unit in Status mode.

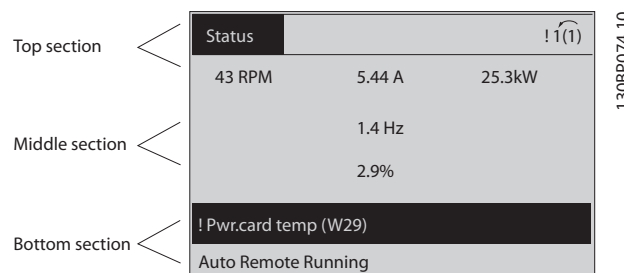

Display contrast adjustment

Press [status] and [▲] for darker display

Press [status] and [▼] for brighter display

Indicator lights (LEDs):

If certain threshold values are exceeded, the alarm and/or warning LED lights up. A status and alarm text appear on the control panel.

The On LED is activated when the unit receives power from mains voltage, a DC bus terminal, or an external 24 V supply. At the same time, the back light is on.

- Green LED/On: Control section is working.
- Yellow LED/Warn.: Indicates a warning.
- Flashing Red LED/Alarm: Indicates an alarm.

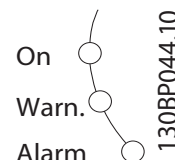

LCP keys

Menu keys

The menu keys are divided into functions. The keys below the display and indicator lamps are used for parameter set-up, including choice of display indication during normal operation.



[Status]

Indicates the status of the filter. Use the [Status] key to toggle single or double readout mode - 5 line readouts, 4 line readouts.

Use [Status] for selecting the mode of display or for changing back to Display mode from either the Quick Menu mode, the Main Menu mode or Alarm mode.

[Quick Menu]

Allows quick set-up of the unit. **The most common functions can be programmed here.**

The [Quick Menu] consists of:

- Q1: My Personal Menu
- Q2: Quick Setup
- Q5: Changes Made
- Q6: Loggings

The Quick Menu parameters can be accessed immediately unless a password has been created via par. 0-60, 0-61, 0-65 or 0-66.

It is possible to switch directly between Quick Menu mode and Main Menu mode.

[Main Menu]

is used for programming all parameters.

The Main Menu parameters can be accessed immediately unless a password has been created via par. 0-60, 0-61, 0-65 or 0-66.

It is possible to switch directly between Main Menu mode and Quick Menu mode.

Parameter shortcut can be carried out by pressing down the [Main Menu] key for 3 seconds. The parameter shortcut allows direct access to any parameter.

[Alarm Log]

displays an Alarm list of the five latest alarms (numbered A1-A5). To obtain additional details about an alarm, use the arrow keys to manoeuvre to the alarm number and press [OK]. Information is displayed about the condition of the unit before it enters the alarm mode.

[Back]

reverts to the previous step or layer in the navigation structure.

[Cancel]

last change or command will be cancelled as long as the display has not been changed.

[Info]

displays information about a command, parameter, or function in any display window. [Info] provides detailed information when needed.

Exit Info mode by pressing either [Info], [Back], or [Cancel].

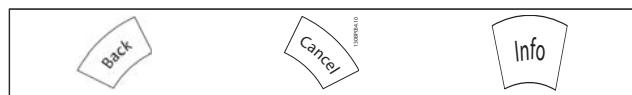

Navigation keys

The four navigation arrows are used to navigate between the different choices available in [Quick Menu], [Main Menu] and [Alarm Log]. Use the keys to move the cursor.

[OK]

is used for choosing a parameter marked by the cursor and for enabling the change of a parameter.

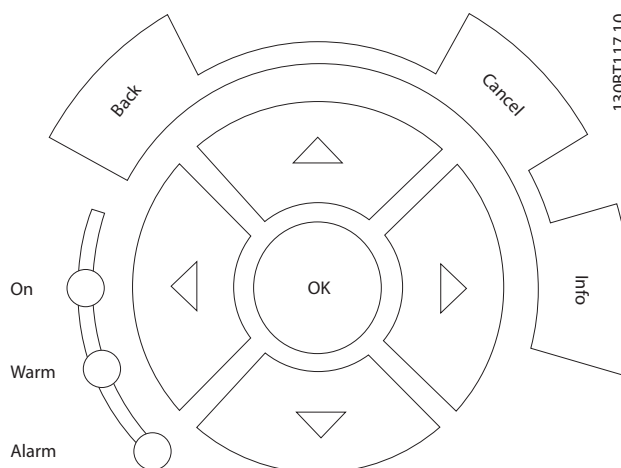

Operation keys

for local control are found at the bottom of the control panel.

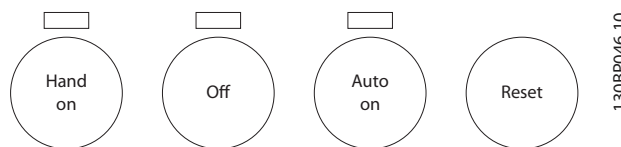

[Hand on]

enables control of the filter via the LCP. The key can be Enabled [1] or Disabled [0] via par. 0-40 [Hand on] Key on LCP.

The following control signals will still be active when [Hand on] is activated:

- [Hand on] - [Off] - [Auto on]
- Reset
- Stop command from serial communication

NOTE

External stop signals activated by means of control signals or a serial bus will override a "start" command via the LCP.

[Off]

stops the unit. The key can be Enabled [1] or Disabled [0] via par. 0-41 [Off] key on LCP. If no external stop function is selected and the [Off] key is inactive the unit can only be stopped by disconnecting the mains supply.

[Auto on]

enables the unit to be controlled via the control terminals and/or serial communication. When a start signal is applied on the control terminals and/or the bus, the unit will start. The key can be Enabled [1] or Disabled [0] via par. 0-42 [Auto on] key on LCP.

NOTE

An active HAND-OFF-AUTO signal via the digital inputs has higher priority than the control keys [Hand on] – [Auto on].

[Reset]

is used for resetting the filter after an alarm (trip). The key can be *Enabled* [1] or *Disabled* [0] via par. 0-43 *Reset Keys on LCP*.

The parameter shortcut

can be carried out by holding down the [Main Menu] key for 3 seconds. The parameter shortcut allows direct access to any parameter.

5.1.2 Changing Data

The procedure for changing data is the same whether you select a parameter in the Quick menu or the Main menu mode. Press [OK] to change the selected parameter. The procedure for changing data depends on whether the selected parameter represents a numerical data value or a text value.

5.1.3 Changing a Text Value

If the selected parameter is a text value, change the text value by means of the up/down navigation keys. The up key increases the value, and the down key decreases the value. Place the cursor on the value to be saved and press [OK].

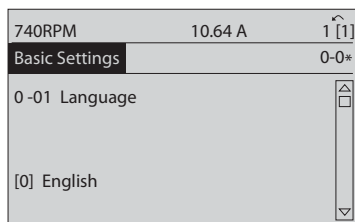

Illustration 5.1: Display example.

5.1.4 Changing a Group of Numeric Data Values

If the chosen parameter represents a numeric data value, change the chosen data value by means of the [←] and [→] navigation keys as well as the up/down [▲] [▼] navigation keys. Use the [←] and [→] navigation keys to move the cursor horizontally.

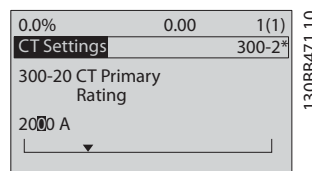

Illustration 5.2: Display example.

Use the up/down navigation keys to change the data value. The up key enlarges the data value, and the down key reduces the data value. Place the cursor on the value to be saved and press [OK].

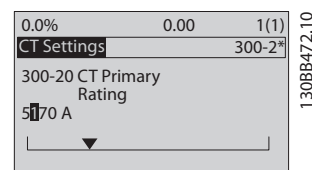

Illustration 5.3: Display example.

5.1.5 Read-out and Programming of Indexed Parameters

Parameters are indexed when placed in a rolling stack. Par. 15-30 *Alarm Log: Error Code* to par. 15-32 *Alarm Log: Time* contain a fault log which can be read out. Choose a parameter, press [OK], and use the up/down navigation keys to scroll through the value log.

Use par. 3-10 *Preset Reference* as another example: Choose the parameter, press [OK], and use the up/down navigation keys to scroll through the indexed values. To change the parameter value, select the indexed value and press [OK]. Change the value by using the up/down keys. Press [OK] to accept the new setting. Press [Cancel] to abort. Press [Back] to leave the parameter.

5.1.6 Tips and Tricks

- The AAF hold standard parameters to ensure lowest possible need of changes. For the majority of applications the Quick Menu, Quick Set-up provides the simplest and quickest access to all the typical parameters required.
- Performing an Auto CT for all standalone filters to set correct current sensor setup. Auto CT setup is only possible if CT's are installed at Point of common coupling PCC (towards the transformer). CT of LHD is preset from factory.
- Under [Quick Menu] and [Changes Made], any parameter that has been changed from factory settings is displayed.
- Press and hold the [Main Menu] key for 3 seconds to access any parameter
- For service purposes, it is recommended to copy all of the parameters to the LCP, see par. 0-50 LCP Copy for further information.

5.1.7 Quick Transfer of Parameter Settings between Multiple Active Filters

Once the set-up of a Filter is complete, we recommend that you store the data in the LCP or on a PC via MCT 10 Set-up Software Tool.

Data storage in LCP:

1. Go to par. 0-50 LCP Copy
2. Press the [OK] key
3. Select "All to LCP"
4. Press the [OK] key

All parameter settings are now stored in the LCP indicated by the progress bar. When 100% is reached, press [OK].

You can now connect the LCP to another filter and copy the parameter settings to this unit as well.

Data transfer from LCP to Filter:

1. Go to par. 0-50 LCP Copy
2. Press the [OK] key
3. Select "All from LCP"
4. Press the [OK] key

The parameter settings stored in the LCP are now transferred to the filter indicated by the progress bar. When 100% is reached, press [OK].

5.1.8 Initialisation to Default Settings

There are two ways to initialise the filter to default: recommended initialisation and manual initialisation. Please be aware that they have different impact according to the below description.

Recommended initialisation (via par. 14-22 Operation Mode)

1. Select par. 14-22 *Operation Mode*
2. Press [OK]
3. Select "Initialisation" (for NLCP select "2")
4. Press [OK]
5. Remove power to unit and wait for display to turn off.
6. Reconnect power and the unit is reset. Note that first start-up takes a few more seconds
7. Press [Reset]

Par. 14-22 <i>Operation Mode</i> initialises all except:
Par. 14-50 <i>RFI Filter</i>
Par. 8-30 <i>Protocol</i>
Par. 8-31 <i>Address</i>
Par. 8-32 <i>Baud Rate</i>
Par. 8-35 <i>Minimum Response Delay</i>
Par. 8-36 <i>Max Response Delay</i>
Par. 8-37 <i>Maximum Inter-Char Delay</i>
Par. 15-00 <i>Operating Hours</i> to par. 15-05 <i>Over Volt's</i>
Par. 15-20 <i>Historic Log: Event</i> to par. 15-22 <i>Historic Log: Time</i>
Par. 15-30 <i>Alarm Log: Error Code</i> to par. 15-32 <i>Alarm Log: Time</i>

NOTE

Parameters selected in par. 0-25 *My Personal Menu*, will stay present, with default factory setting.

Manual initialisation

NOTE

When carrying out manual initialisation, serial communication and fault log settings are reset.

1. Disconnect from mains and wait until the display turns off.
- 2a. Press [Status] - [Main Menu] - [OK] at the same time while power up for LCP
- 2b. Press [Menu] while power up for LCP 101, Numerical Display
3. Release the keys after 5 s
4. The active filter is now programmed according to default settings

This parameter initialises all except:
Par. 15-00 <i>Operating Hours</i>
Par. 15-03 <i>Power Up's</i>
Par. 15-04 <i>Over Temp's</i>
Par. 15-05 <i>Over Volt's</i>

5.1.9 RS-485 Bus Connection

The filter can be connected to a controller (or master) together with other loads using the RS-485 standard interface. Terminal 68 is connected to the P signal (TX+, RX+), while terminal 69 is connected to the N signal (TX-,RX-).

5

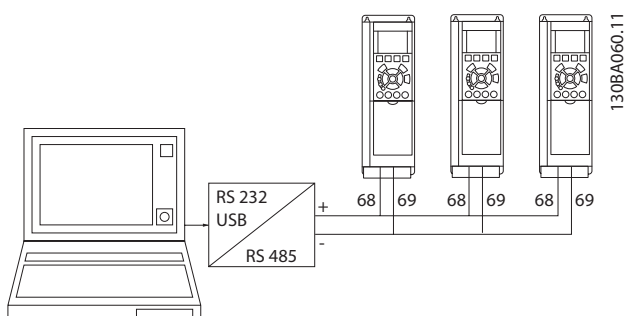

Illustration 5.4: Connection example.

In order to avoid potential equalizing currents in the screen, earth the cable screen via terminal 61, which is connected to the frame via an RC-link.

Bus termination

The RS-485 bus must be terminated by a resistor network at both ends. If the unit is the first or the last device in the RS-485 loop, set the switch S801 on the control card for ON..

5.1.10 How to Connect a PC to the Active Filter

To control or program the Filter from a PC, install the PC-based Configuration Tool MCT 10. The PC is connected via a standard (host/device) USB cable to both devices, or via the RS-485 interface

NOTE

The USB connection is galvanically isolated from the supply voltage (PELV) and other high-voltage terminals. The USB connection is connected to protection earth on the Active Filter. Use only an isolated laptop as PC connection to the USB connector on the Active Filter.

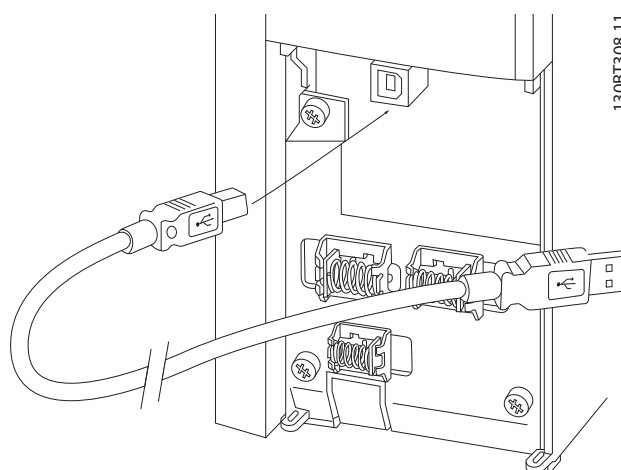

Illustration 5.5: For control cable connections, see section on Control Terminals.

5.1.11 PC Software Tools

PC-based Configuration Tool MCT 10

The Active Filter is equipped with one serial communication ports. Danfoss provides a PC tool for communication between PC and filter, PC-based Configuration Tool MCT 10. Please consult the MCT 10 software where build in literature can reveal more usefull information.

MCT 10 set-up software

MCT 10 has been designed as an easy to use interactive tool for setting parameters in our Active Filters. The software can be downloaded from the Danfoss internet site <http://www.Danfoss.com/BusinessAreas/DrivesSolutions/Software-download/DDPC+Software+Program.htm>.

The MCT 10 set-up software will be useful for:

- Planning a communication network off-line. MCT 10 contains a complete active filter database
- Commissioning active filters on line
- Saving settings for all active filters
- Replacing an active filter in a network
- Simple and accurate documentation of active filter settings after commissioning.
- Expanding an existing network
- Future developed active filters will be supported

Save filter settings:

1. Connect a PC to the unit via USB com port. (NOTE: Use a PC, which is isolated from the mains, in conjunction with the USB port. Failure to do so may damage equipment.)
2. Open MCT 10 Set-up Software
3. Choose "Read from drive"
4. Choose "Save as"

All parameters are now stored in the PC.

Load filter settings:

1. Connect a PC to the unit via USB com port
2. Open MCT 10 Set-up software
3. Choose "Open"– stored files will be shown
4. Open the appropriate file
5. Choose "Write to drive"

All parameter settings are now transferred to the filter.

A separate manual for MCT 10 Set-up Software is available:
MG.10.Rx.yy.

The MCT 10 Set-up software modules

The following modules are included in the software package:

	MCT Set-up 10 Software
	Setting parameters Copy to and from unit Documentation and print out of parameter settings incl. diagrams
	Ext. user interface
	Preventive Maintenance Schedule Clock settings Timed Action Programming Smart Logic Controller Set-up

Ordering number:

Please order the CD containing MCT 10 Set-up Software using code number 130B1000.

MCT 10 can also be downloaded from the Danfoss Internet:
WWW.DANFOSS.COM, Business Area: Motion Controls.

6 How to Programme

6.1.1 Parameter Set-up

The factory settings for the Active Filter are chosen for optimal operation for most applications with a minimum of additional programming. The filter is set in overall harmonic compensation mode with harmonic current priority. Selection of read-outs and what information to be displayed on the LCP status lines can be made to fit individual preferences. The filter will only in a few cases have to be tuned specially for the given grid and load conditions.

The following steps are often sufficient, to set up the filter and get proper operation:

- Check that the nominal voltage in par. 300-10 is correct
- Program the external CT's:
 - Check the CT-location is correct in par. 300-26
 - Enter CT Secondary Rating par. 300-21
 - Activate the Auto CT Detection in par. 300-29
 - Confirm the found CT-ratio, polarity and sequence.
- Make sure the filter is in auto mode (press the Auto On button on the LCP)

Overview of all parameter groups:

Group	Title	Function
0-	Operation / Display	Parameters related to the fundamental functions of the filter, function of the LCP buttons and configuration of the LCP display.
5-	Digital In/Out	Parameter group for configuring the digital inputs and outputs.
8-	Communication and Options	Parameter group for configuring communications and options.
14-	Special Functions	Parameter group for configuring special filter functions.
15-	Unit Information	Parameter group containing filter information such as operating data, hardware configuration and software versions.
16-	Data Readouts	Parameter group for data read-outs, e.g. actual references, voltages, control, alarm, warning and status words.
300-	AF Settings	Parameter group for setting the Active Filter. Apart from par. 300-10, Active Filter Nominal Voltage, it is not recommended to change the settings of this parameter group.
301-	AF Readouts	Parameter group for the filter readouts.

Table 6.1: Parameter groups

Parameter descriptions and selections are displayed on the graphic (LCP) display area. (See Section 5 for details.) Access the parameters by pressing the [Quick Menu] or [Main Menu] key on the control panel. The quick menu is used primarily for commissioning the unit at start-up by providing those parameters necessary to start operation. The main menu provides access to all parameters for detailed application programming. All digital input/output terminals are multifunctional. All terminals have factory default functions suitable for the majority of applications but if other special functions are required, they must be programmed in parameter group 5.

6.1.2 Quick Menu Mode

The GLCP provides access to all parameters listed under the Quick Menus. To set parameters using the [Quick Menu] button:

Pressing [Quick Menu] the list indicates the different areas contained in the Quick menu.

Efficient parameter set-up for most applications

The parameters can easily be set up for the majority of the applications only by using the [Quick Menu].

The optimum way to set parameters through the [Quick Menu] is by following the below steps:

1. Press [Quick Setup] for selecting language, compensation mode, CT-setup, etc.
2. Press [My personal Menu] to setup the LCP readout parameters. If preset display is acceptable this operation can be left out.

It is recommended to do the set-up in the order listed.

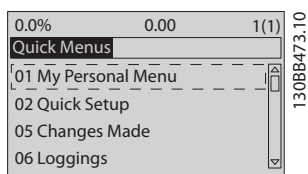

Illustration 6.1: Quick Menu view.

If *No Operation* is selected in terminal 27 no connection to +24 V on terminal 27 is necessary to enable start.

If *Coast Inverse* is selected in Terminal 27, a connection to +24V is necessary to enable start.

6.1.3 Q1 My Personal Menu

Parameters defined by the user can be stored in Q1 My Personal Menu. Select My Personal Menu to display only the parameters, which have been pre-selected and programmed as personal parameters. A large scale Active filter user may have pre-programmed important setup values in the My Personal Menu to make on site commissioning / fine tuning simpler. These parameters are selected in par. 0-25 My Personal Menu. Up to 20 different parameters can be defined in this menu.

Q1 My Personal Menu		
Parameter number	Name	Factory default
0-01	Language	English
0-20	Display Line 1.1 Small	Power Factor
0-21	Display Line 1.2 Small	THD of current
0-22	Display Line 1.3 Small	Mains current
0-23	Display Line 2 Large	Output current (corrected)
0-24	Display Line 3 Large	Mains frequency
15-51	Unit serial number	

6.1.4 Q2 Quick Setup

The parameters in Q2 Quick Setup are the basic parameters which are always needed to set-up the Active Filter to operation.

Q2 Quick Setup		
Parameter number	Name	Factory default
0-01	Language	English
300-10	Active Filter Nominal Voltage	400V
300-22	CT Nominal Voltage	Same as AF
300-21	CT Secondary rating	5A
300-29	Start Auto CT detection	Off
300-01	Compensation Priority	Harmonics
300-00	Harmonic cancellation mode	Overall

NOTE

It is necessary to set the nominal voltage and CT Secondary rating, as well as change par. 300-26 to PCC, before the Auto CT detection is started. Auto CT detection is only possible if CTs are located at the point of common coupling.

6.1.5 Q5 Changes Made

Q5 Changes Made can be used for fault finding.

Select Changes made to get information about:

- • the last 10 changes. Use the up/down navigation keys to scroll between the last 10 changed parameters.
- the changes made since default setting.

6.1.6 Q6 Loggings

Q6 Loggings can be used for fault finding.

Select Loggings to get information about the display line read-outs. The information is shown as graphs. Only display parameters selected in par. 0-20 and par. 0-24 can be viewed. It is possible to store up to 120 samples in the memory for later reference.

Please notice that the parameters listed in the below table for Q6 only serve as examples as they will vary depending on the programming of the particular Active Filter.

Q6 Loggings		
0-20	Display Line 1.1 Small	Power Factor
0-21	Display Line 1.2 Small	THD of current
0-22	Display Line 1.3 Small	Mains Current
0-23	Display Line 2 Large	Output Current
0-24	Display Line 3 Large	Mains Frequency

6.1.7 Main Menu mode

The LCP provide access to the main menu mode. Select the Main Menu mode by pressing the [Main Menu] key. Illustration 6.2 shows the resulting read-out, which appears on the display of the GLCP.

Lines 2 through 5 on the display show a list of parameter groups which can be chosen by toggling the up and down buttons.

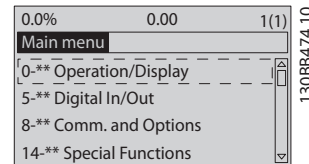

Illustration 6.2: Display example.

Each parameter has a name and number which remain the same regardless of the programming mode. In the Main Menu mode, the parameters are divided into groups. The first digit of the parameter number (from the left) indicates the parameter group number. All parameters can be changed in the Main Menu. Option cards added to the unit enable additional parameters associated with the option device.

6.1.8 Parameter Selection

In the Main Menu mode, the parameters are divided into groups. Select a parameter group by means of the navigation keys.

The following parameter groups are accessible:

Group	Title	Function
0-	Operation / Display	Parameters related to the fundamental functions of the filter, function of the LCP buttons and configuration of the LCP display.
5-	Digital In/Out	Parameter group for configuring the digital inputs and outputs.
8-	Communication and Options	Parameter group for configuring communications and options.
14-	Special Functions	Parameter group for configuring special filter functions.
15-	Unit Information	Parameter group containing filter information such as operating data, hardware configuration and software versions.
16-	Data Readouts	Parameter group for data read-outs, e.g. actual references, voltages, control, alarm, warning and status words.
300-	AF Settings	Parameter group for setting the Active Filter. Apart from par. 300-10, Active Filter Nominal Voltage, it is not recommended to change the settings of this parameter group.
301--	AF Readouts	Parameter group for the filter readouts.

Table 6.2: Parameter groups

After selecting a parameter group, choose a parameter by means of the navigation keys. The middle section on the GLCP display shows the parameter number and name as well as the selected parameter value.

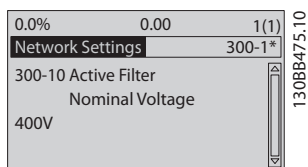

Illustration 6.3: Display example.

6.1 Description of Parameters

6.2.1 Main Menu

The Main Menu includes all available parameters in the VLT® Active Filter AAF 005. All parameters are grouped in a logic way with a group name indicating the function of the parameter group. All parameters are listed by name and number in the following section. A quicker overview can be found in the Parameter Lists later in this manual.

6.2.2 0-** Operation / Display

Parameters related to the fundamental functions of the Active Filter, function of the LCP buttons and configuration of the LCP display.

6.2.3 0-0* Basic Settings

0-01 Language		
Option:	Function:	
		Defines the language to be used in the display. The filter can be delivered with 4 different language packages. English and German are included in all packages. English cannot be erased or manipulated.
[0] *	English	Part of Language packages 1 - 4
[1]	Deutsch	Part of Language packages 1 - 4
[2]	Francais	Part of Language package 1
[3]	Dansk	Part of Language package 1
[4]	Spanish	Part of Language package 1
[5]	Italiano	Part of Language package 1
	Svenska	Part of Language package 1
[7]	Nederlands	Part of Language package 1
[10]	Chinese	Part of Language package 2
	Suomi	Part of Language package 1
[22]	English US	Part of Language package 4
	Greek	Part of Language package 4
	Bras.port	Part of Language package 4
	Slovenian	Part of Language package 3
	Korean	Part of Language package 2
	Japanese	Part of Language package 2
	Turkish	Part of Language package 4
	Trad.Chinese	Part of Language package 2
	Bulgarian	Part of Language package 3

0-01 Language		
Option:	Function:	
	Srpski	Part of Language package 3
	Romanian	Part of Language package 3
	Magyar	Part of Language package 3
	Czech	Part of Language package 3
	Polski	Part of Language package 4
	Russian	Part of Language package 3
	Thai	Part of Language package 2
	Bahasa Indonesia	Part of Language package 2
[99]	Unknown	

0-04 Operating State at Power-up (Hand)		
Option:	Function:	
		Selects the operating mode upon reconnection of the filter to mains voltage after power down in Hand (local) operation mode.
[0]	Resume	Restarts the filter maintaining the same local reference and the same start/stop settings (applied by [HAND ON/OFF]) as before the filter was powered down.
[1] *	Forced stop, ref=old	Restarts the filter with a saved local reference, after mains voltage reappears and after pressing [HAND ON].
[2]	Forced stop, ref=0	Resets the local reference to 0 upon restarting the filter.

6.2.4 0-1* Set-up Operations

Define and control the individual parameter setups.

The filter has four parameter setups that can be programmed independently of each other. This makes the filter very flexible and able to solve advanced control functionality problems, often saving the cost of external control equipment. For example these can be used to program the filter to operate according to one control scheme in one setup and another control scheme in another setup.

The active setup (i.e. the setup in which the filter is currently operating) can be selected in par. 0-10 *Active Set-up* and is displayed in the LCP. Using Multi set-up it is possible to switch between setups with the filter running or stopped, via digital input or serial communication commands. If it is necessary to change setups whilst running, ensure par. 0-12 *This Set-up Linked to* is programmed as required. Using par. 0-11 *Edit Set-up* it is possible to edit parameters within any of the setups whilst continuing the filter operation in its Active Setup which can be a different setup to that being edited. Using par. 0-51 *Set-up Copy* it is possible to copy parameter settings between the setups to enable quicker commissioning if similar parameter settings are required in different setups.

0-10 Active Set-up		
Option:	Function:	
		Select the set-up to control the filter functions.
[0]	Factory setup	Cannot be changed. It contains the Danfoss data set, and can be used as a data source when returning the other set-ups to a known state.
[1] *	Set-up 1	Set-up 1 [1] to Set-up 4 [4] are the four separate parameter set-ups within which all parameters can be programmed.
[2]	Set-up 2	
[3]	Set-up 3	
[4]	Set-up 4	
[9]	Multi Set-up	Remote selection of set-ups using digital inputs and the serial communication port. This set-up uses the settings from par. 0-12 <i>This Set-up Linked to</i> . Stop the filter before making changes to open- and closed loop functions

Use par. 0-51 *Set-up Copy* to copy a set-up to one or all other set-ups. Stop the filter before switching between set-ups where parameters marked 'not changeable during operation' have different values. To avoid conflicting settings of the same parameter within two different set-ups, link the set-ups together using par. 0-12 *This Set-up Linked to*. Parameters which are 'not changeable during operation' are marked FALSE in the parameter lists in the section *Parameter Lists*.

0-11 Edit Set-up		
Option:	Function:	
		Select the set-up to be edited (i.e. programmed) during operation; either the active set-up or one of the inactive set-ups.
[0]	Factory setup	Cannot be edited but it is useful as a data source to return the other set-ups to a known state.
[1] *	Set-up 1	Set-up 1 [1] to Set-up 4 [4] can be edited freely during operation, independently of the active set-up.
[2]	Set-up 2	
[3]	Set-up 3	
[4]	Set-up 4	
[9]	Active Set-up	Can also be edited during operation. Edit the chosen set-up from a range of sources: LCP, FC RS-485, FC USB or up to five fieldbus sites.

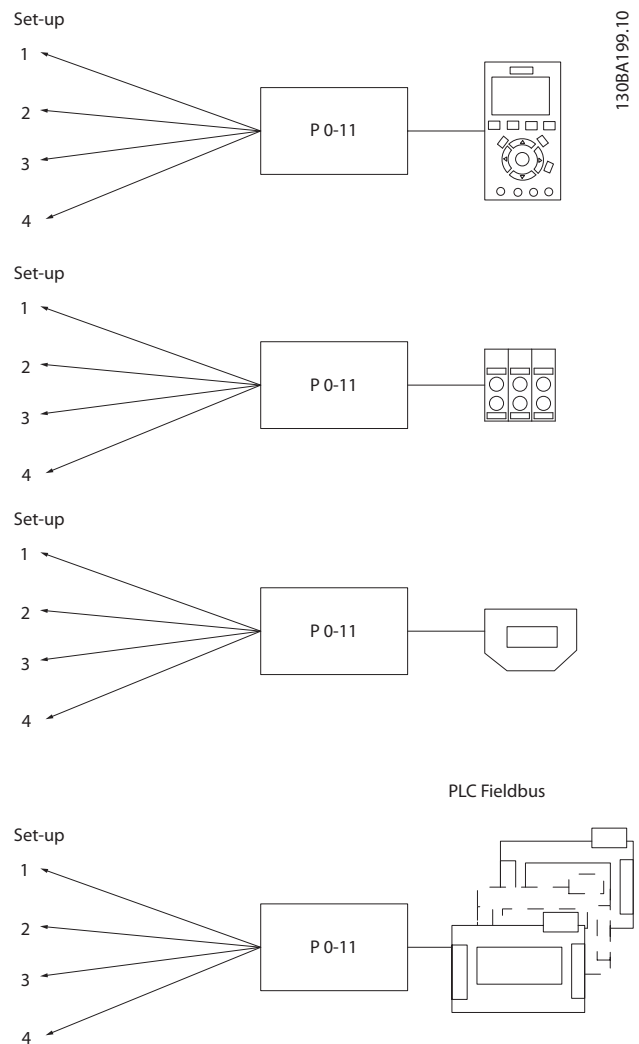

0-12 This Set-up Linked to	
Option:	Function:
	To enable conflict-free changes from one set-up to another during operation, link set-ups containing parameters which are not changeable during operation. The link will ensure synchronising of the 'not changeable during operation' parameter values when moving from one set-up to another during operation. 'Not changeable during operation' parameters can be identified by the label FALSE in the parameter lists in the section <i>Parameter Lists</i> .
	Par. 0-12 <i>This Set-up Linked to</i> is used by Multi set-up in par. 0-10 <i>Active Set-up</i> . Multi set-up is used to move from one set-up to another during operation (i.e. while the motor is running). Example: Use Multi set-up to shift from Set-up 1 to Set-up 2 whilst the motor is running. Programme in Set-up 1 first, then ensure that Set-up 1 and Set-up 2 are synchronised (or 'linked'). Synchronisation can be performed in two ways:

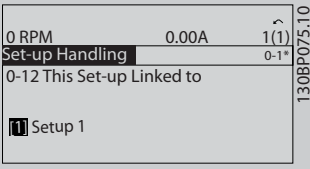
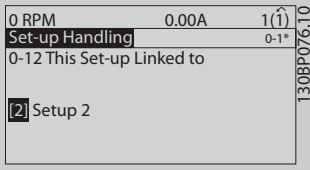
0-12 This Set-up Linked to	
Option:	Function:
	<p>1. Change the edit set-up to <i>Set-up 2</i> [2] in par. 0-11 <i>Edit Set-up</i> and set par. 0-12 <i>This Set-up Linked to</i> to <i>Set-up 1</i> [1]. This will start the linking (synchronising) process.</p>  <p>OR</p> <p>2. While still in Set-up 1, copy Set-up 1 to Set-up 2. Then set par. 0-12 <i>This Set-up Linked to</i> to <i>Set-up 2</i> [2]. This will start the linking process.</p>  <p>After the link is complete, par. 0-13 <i>Readout: Linked Set-ups</i> will read {1,2} to indicate that all 'not changeable during operation' parameters are now the same in Set-up 1 and Set-up 2. If there are changes to a 'not changeable during operation' parameter, e.g. par. 1-30 <i>Stator Resistance (Rs)</i>, in Set-up 2, they will also be changed automatically in Set-up 1. A switch between Set-up 1 and Set-up 2 during operation is now possible.</p>
[0] *	Not linked
[1]	Set-up 1
[2]	Set-up 2
[3]	Set-up 3
[4]	Set-up 4

0-13 Readout: Linked Set-ups													
Range:	Function:												
0 N/A*	[0 - 255] View a list of all the set-ups linked by means of par. 0-12 <i>This Set-up Linked to</i> . The parameter has one index for each parameter set-up. The parameter value displayed for each index represents which setups are linked to that parameter setup.												
	<table border="1"> <thead> <tr> <th>Index</th> <th>LCP value</th> </tr> </thead> <tbody> <tr> <td>0</td> <td>{0}</td> </tr> <tr> <td>1</td> <td>{1,2}</td> </tr> <tr> <td>2</td> <td>{1,2}</td> </tr> <tr> <td>3</td> <td>{3}</td> </tr> <tr> <td>4</td> <td>{4}</td> </tr> </tbody> </table>	Index	LCP value	0	{0}	1	{1,2}	2	{1,2}	3	{3}	4	{4}
Index	LCP value												
0	{0}												
1	{1,2}												
2	{1,2}												
3	{3}												
4	{4}												
<p>Table 6.4: Example: Set-up 1 and Set-up 2 are linked</p>													

0-14 Readout: Edit Set-ups / Channel	
Range:	Function:
0*	[-2147483648 - 2147483647] View the setting of par. 0-11 <i>Edit Set-up</i> for each of the four different communication channels. When the number is displayed in hex, as it is in the LCP, each number represents one channel. Numbers 1-4 represent a set-up number; 'F' means factory setting; and 'A' means active set-up. The channels are, from right to left: LCP, FC-bus, USB, HPFB1-5. Example: The number AAAAAA21h means that the FC bus selected Set-up 2 in par. 0-11 <i>Edit Set-up</i> , the LCP selected Set-up 1 and all others used the active set-up.

6.2.5 0-2* LCP Display

Define the variables displayed in the Graphical Local Control Panel.

NOTE

Please refer to par. 0-37 *Display Text 1*, par. 0-38 *Display Text 2* and par. 0-39 *Display Text 3* for information on how to write display texts.

0-20 Display Line 1.1 Small		
Option:		Function:
		Select a variable for display in line 1, left position.
[1695]	Ext. Status Word 2	One or more status conditions in a Hex code.
[0]	None	No display value selected.
[9]	Performance Monitor	
[37]	Display Text 1	
[38]	Display Text 2	
[39]	Display Text 3	
[953]	Profibus Warning Word	
[1005]	Readout Transmit Error Counter	
[1006]	Readout Receive Error Counter	
[1007]	Readout Bus Off Counter	
[1013]	Warning Parameter	
[1230]	Warning Parameter	
[1472]	Legacy Alarm Word	
[1473]	Legacy Warning Word	
[1474]	Leg. Ext. Status Word	
[1501]	Running Hours	
[1502]	kWh Counter	
[1600]	Control Word	Present control word
[1601]	Reference [Unit]	Total reference (sum of digital/analog/preset/bus/freeze ref./catch up and slow-down) in selected unit.
[1602]	Reference %	Total reference (sum of digital/analog/preset/bus/freeze ref./catch up and slow-down) in percent.
[1603]	Status Word	Present status word.
[1605]	Main Actual Value [%]	Actual value as a percentage.
[1609]	Custom Readout	
[1610]	Power [kW]	Actual power consumed by the motor in kW.
[1611]	Power [hp]	Actual power consumed by the motor in HP.
[1619]	KTY sensor temperature	

0-20 Display Line 1.1 Small		
Option:		Function:
[1620]	Motor Angle	
[1621]	Torque [%] High Res.	
[1622]	Torque [%]	Present motor load as a percentage of the rated motor torque.
[1625]	Torque [Nm] High	
[1630]	DC Link Voltage	Intermediate circuit voltage in the unit.
[1632]	Brake Energy /s	Present brake power transferred to an external brake resistor. Stated as an instantaneous value.
[1633]	Brake Energy /2 min	Brake power transferred to an external brake resistor. The mean power is calculated continuously for the most recent 120 seconds.
[1634]	Heatsink Temp.	Present heat sink temperature of the unit. The cut-out limit is 95 ±5 °C; cutting back in occurs at 70 ±5° C.
[1635]	Inverter Thermal	Percentage load of the inverters.
[1636]	Inv. Nom. Current	Nominal current of the unit.
[1637]	Inv. Max. Current	Maximum current of the unit.
[1638]	SL Controller State	State of the event executed by the control.
[1639]	Control Card Temp.	Temperature of the control card.
[1650]	External Reference	Sum of the external reference as a percentage, i.e. the sum of analog/pulse/bus.
[1651]	Pulse Reference	Frequency in Hz connected to the digital inputs (18, 19 or 32, 33).
[1652]	Feedback [Unit]	Reference value from programmed digital input(s).
[1653]	Digi Pot Reference	
[1660]	Digital Input	Signal states form the 6 digital terminals (18, 19, 27, 29, 32 and 33). There are 16 bits in total, but only six of them are used. Input 18 corresponds to the leftmost of the used bits. Signal low = 0; Signal high = 1.
[1661]	Terminal 53 Switch Setting	Setting of input terminal 54. Current = 0; Voltage = 1.
[1662]	Analog Input 53	Actual value at input 53 either as a reference or protection value.
[1663]	Terminal 54 Switch Setting	Setting of input terminal 54. Current = 0; Voltage = 1.
[1664]	Analog Input 54	Actual value at input 54 either as reference or protection value.
[1665]	Analog Output 42 [mA]	Actual value at output 42 in mA. Use par. 6-50 <i>Terminal 42 Output</i> to select the value to be shown.
[1666]	Digital Output [bin]	Binary value of all digital outputs.
[1667]	Freq. Input #29 [Hz]	Actual value of the frequency applied at terminal 29 as an impulse input.

0-20 Display Line 1.1 Small		
Option:	Function:	
[1668]	Freq. Input #33 [Hz]	Actual value of the frequency applied at terminal 33 as an impulse input.
[1669]	Pulse Output #27 [Hz]	Actual value of impulses applied to terminal 27 in digital output mode.
[1670]	Pulse Output #29 [Hz]	Actual value of impulses applied to terminal 29 in digital output mode.
[1671]	Relay Output [bin]	
[1672]	Counter A	Application dependent (e.g. SLC Control)
[1673]	Counter B	Application dependent (e.g. SLC Control)
[1674]	Prec. Stop Counter	Display the actual counter value.
[1675]	Analog In X30/11	Actual value at input X30/11 either as reference or protection value.
[1676]	Analog In X30/12	Actual value at input X30/12 either as reference or protection value.
[1677]	Analog Out X30/8 [mA]	Actual value at output X30/8 in mA. Use par. 6-60 <i>Terminal X30/8 Output</i> to select the value to be shown.
[1678]	Analog Out X45/1 [mA]	
[1679]	Analog Out X45/3 [mA]	
[1680]	Fieldbus CTW 1	Control word (CTW) received from the Bus Master.
[1682]	Fieldbus REF 1	Main reference value sent with control word from the Bus Master.
[1684]	Comm. Option STW	Extended fieldbus communication option status word.
[1685]	FC Port CTW 1	Control word (CTW) received from the Bus Master.
[1686]	FC Port REF 1	Status word (STW) sent to the Bus Master.
[1690]	Alarm Word	One or more alarms in a Hex code.
[1691]	Alarm Word 2	One or more alarms in a Hex code.
[1692]	Warning Word	One or more warnings in a Hex code.
[1693]	Warning Word 2	One or more warnings in a Hex code.
[1694]	Ext. Status Word	One or more status conditions in a Hex code.
[1836]	Analog Input X48/2 [mA]	
[1837]	Temp. Input X48/4	
[1838]	Temp. Input X48/7	
[1839]	Temp. Input X48/10	
[1860]	Digital Input 2	
[1890]	Process PID Error	
[1891]	Process PID Output	
[1892]	Process PID Clamped Output	
[1893]	Process PID Gain Scaled Output	

0-20 Display Line 1.1 Small		
Option:	Function:	
[3019]	Wobble Delta Freq. Scaled	
[3110]	Bypass Status Word	
[3111]	Bypass Running Hours	
[3401]	PCD 1 Write to MCO	
[3402]	PCD 2 Write to MCO	
[3403]	PCD 3 Write to MCO	
[3404]	PCD 4 Write to MCO	
[3405]	PCD 5 Write to MCO	
[3406]	PCD 6 Write to MCO	
[3407]	PCD 7 Write to MCO	
[3408]	PCD 8 Write to MCO	
[3409]	PCD 9 Write to MCO	
[3410]	PCD 10 Write to MCO	
[3421]	PCD 1 Read from MCO	
[3422]	PCD 2 Read from MCO	
[3423]	PCD 3 Read from MCO	
[3424]	PCD 4 Read from MCO	
[3425]	PCD 5 Read from MCO	
[3426]	PCD 6 Read from MCO	
[3427]	PCD 7 Read from MCO	
[3428]	PCD 8 Read from MCO	
[3429]	PCD 9 Read from MCO	
[3430]	PCD 10 Read from MCO	
[3440]	Digital Inputs	
[3441]	Digital Outputs	
[3450]	Actual Position	
[3451]	Commanded Position	
[3452]	Actual Master Position	
[3453]	Slave Index Position	
[3454]	Master Index Position	
[3455]	Curve Position	
[3456]	Track Error	
[3457]	Synchronizing Error	
[3458]	Actual Velocity	
[3459]	Actual Master Velocity	
[3460]	Synchronizing Status	

0-20 Display Line 1.1 Small		
Option:	Function:	
[3461]	Axis Status	
[3462]	Program Status	
[3464]	MCO 302 Status	
[3465]	MCO 302 Control	
[3470]	MCO Alarm Word 1	
[3471]	MCO Alarm Word 2	
[9913]	Idle time	
[9914]	Paramdb requests in queue	
[9917]	tCon1 time	
[9918]	tCon2 time	
[9919]	Time Optimize Measure	
[9920]	HS Temp. (PC1)	
[9921]	HS Temp. (PC2)	
[9922]	HS Temp. (PC3)	
[9923]	HS Temp. (PC4)	
[9924]	HS Temp. (PC5)	
[9925]	HS Temp. (PC6)	
[9926]	HS Temp. (PC7)	
[9927]	HS Temp. (PC8)	

0-21 Display Line 1.2 Small		
Option:	Function:	
[1614] *	Motor Current	Select a variable for display in line 1, middle position. The options are the same as listed for par. 0-20.

0-22 Display Line 1.3 Small		
Option:	Function:	
[1610] *	Power [kW]	Select a variable for display in line 1, right position. The options are the same as listed for par. 0-20.

0-23 Display Line 2 Large		
Option:	Function:	
[1613] *	Frequency	Select a variable for display in line 2. The options are the same as listed for par. 0-20.

0-24 Display Line 3 Large		
Select a variable for display in line 3.		
Option:	Function:	
[1502] *	kWh Counter	The options are the same as those listed in par. 0-20 <i>Display Line 1.1 Small</i> .

0-25 My Personal Menu		
Range:	Function:	
Application dependent*	[0 - 9999]	Define up to 50 parameters to appear in the Q1 Personal Menu, accessible via the [Quick Menu] key on the LCP. The parameters will be displayed in the Q1 Personal Menu in the order they are programmed into this array parameter. Delete parameters by setting the value to '0000'. For example, this can be used to provide quick, simple access to just one or up to 50 parameters which require changing on a regular basis (e.g. for plant maintenance reasons) or by an OEM to enable simple commissioning of their equipment.

6.2.6 0-4* LCP Keypad

Enable, disable and password protect individual keys on the LCP.

0-40 [Hand on] Key on LCP		
Option:	Function:	
[0]	Disabled	No effect when [Hand on] is pressed. Select [0] Disabled to avoid accidental start of the drive in <i>Hand on</i> mode.
[1] *	Enabled	The LCP switches to <i>Hand on</i> mode directly when [Hand on] is pressed.
[2]	Password	After pressing [Hand on] a password is required. If par. 0-40 is included in <i>My Personal Menu</i> , define the password in par. 0-65, <i>Personal Menu Password</i> . Otherwise define the password in par. 0-60, <i>Main Menu Password</i>
[3]	Hand Off/On	When [Hand on] is pressed once, the LCP switches to <i>Off</i> mode. When pressed again, the LCP switches to <i>Hand on</i> mode.
[4]	Hand Off/On w. Passw.	Same as [3] but a password is required (see [2]).

0-41 [Off] Key on LCP		
Option:	Function:	
[0] *	Disabled	Avoids accidental stop of the unit.
[1] *	Enabled	
[2]	Password	Avoids unauthorised stop. If par. 0-41 [Off] Key on LCP is included in the Quick Menu, then define the password in par. 0-65 <i>Quick Menu Password</i> .

0-42 [Auto on] Key on LCP		
Option:	Function:	
[0] *	Disabled	Avoid accidental start of the unit in Auto mode.
[1] *	Enabled	
[2]	Password	Avoids unauthorised start in Auto mode. If par. 0-42 [Auto on] Key on LCP is included in the Quick Menu, then define the password in par. 0-65 Quick Menu Password.

0-43 [Reset] Key on LCP		
Option:	Function:	
[0] *	Disabled	No effect when [Reset] is pressed. Avoids accidental alarm reset.
[1] *	Enabled	
[2]	Password	Avoids unauthorised resetting. If par. 0-43 [Reset] Key on LCP is included in the Quick Menu, then define the password in par. 0-65 Quick Menu Password.
[7]	Enabled without OFF	Resets the drive without setting it in Off mode.
[8]	Password without OFF	Resets the drive without setting it in Off mode. A password is required when pressing [Reset] (see [2]).

6.2.7 0-5* Copy / Save

Copy parameter settings between set-ups and to/from the LCP.

0-50 LCP Copy		
Option:	Function:	
[0] *	No copy	
[1]	All to LCP	Copies all parameters in all set-ups from the filter memory to the LCP memory.
[2]	All from LCP	Copies all parameters in all set-ups from the LCP memory to the filter memory.
[3]	Size indep. from LCP	Copy only the parameters that are independent of the motor size. The latter selection can be used to programme several filters with the same function without disturbing motor data.
[4]	File from MCO to LCP	
[5]	File from LCP to MCO	
[6]	Data from DYN to LCP	
[7]	Data from LCP to DYN	
[8]	LCP Compare	

This parameter cannot be adjusted while the motor is running.

0-51 Set-up Copy		
Option:	Function:	
[0] *	No copy	No function
[1]	Copy to set-up 1	Copies all parameters in the present Programming Set-up (defined in par. 0-11 Programming Set-up) to Set-up 1.
[2]	Copy to set-up 2	Copies all parameters in the present Programming Set-up (defined in par. 0-11 Programming Set-up) to Set-up 2.
[3]	Copy to set-up 3	Copies all parameters in the present Programming Set-up (defined in par. 0-11 Programming Set-up) to Set-up 3.
[4]	Copy to set-up 4	Copies all parameters in the present Programming Set-up (defined in par. 0-11 Programming Set-up) to Set-up 4.
[9]	Copy to all	Copies the parameters in the present set-up over to each of the set-ups 1 to 4.

6.2.8 0-6* Password

0-60 Main Menu Password		
Range:	Function:	
100 N/A*	[0 - 999 N/A]	Define the password for access to the Main Menu via the [Main Menu] key. If par. 0-61 Access to Main Menu w/o Password is set to Full access [0], this parameter will be ignored.

0-61 Access to Main Menu w/o Password		
Option:	Function:	
[0] *	Full access	Disables password defined in par. 0-60 Main Menu Password.
[1]	LCP: Read only	Prevent unauthorized editing of Main Menu parameters.
[2]	LCP: No access	Prevent unauthorized viewing and editing of Main Menu parameters.
[3]	Bus: Read only	Read-only functions for parameters on fieldbus and/or FC standard bus.
[4]	Bus: No access	No access to parameters is allowed via fieldbus and/or FC standard bus.
[5]	All: Read only	Read-only function for parameters on LCP, fieldbus or FC standard bus.
[6]	All: No access	No access from LCP, fieldbus or FC standard bus is allowed.

If Full access [0] is selected then par. 0-60 Main Menu Password, par. 0-65 Personal Menu Password and par. 0-66 Access to Personal Menu w/o Password will be ignored.

0-65 Quick Menu Password		
Range:	Function:	
200* [-9999 - 9999]	Define the password for access to the Quick Menu via the [Quick Menu] key. If par. 0-66 <i>Access to Quick Menu w/o Password</i> is set to <i>Full access</i> [0], this parameter will be ignored.	

0-66 Access to Quick Menu w/o Password		
Option:	Function:	
[0] *	Full access	Disables the password defined in par. 0-65 <i>Quick Menu Password</i> .
[1]	LCP: Read only	Prevents unauthorised editing of Quick Menu parameters.
[2]	LCP: No access	Prevents unauthorised viewing and editing of Quick Menu parameters.
[3]	Bus: Read only	Read only functions for Quick Menu parameters on fieldbus and/ or FC standard bus.
[4]	Bus: No access	No access to Quick Menu parameters is allowed via fieldbus and/ or FC standard bus.
[5]	All: Read only	read only function for Quick Menu parameters on LCP, fieldbus or FC standard bus.
[6]	All: No access	No access from LCP, fieldbus or FC standard bus is allowed.

If par. 0-61 *Access to Main Menu w/o Password* is set to *Full access* [0] then this parameter will be ignored.

6.2.9 5-0* Digital I/O Mode

Parameters for configuring the input and output using NPN and PNP.

These parameters cannot be adjusted while motor is running.

5-00 Digital I/O Mode		
Option:	Function:	
		Digital inputs and programmed digital outputs are pre-programmable for operation either in PNP or NPN systems.
[0] *	PNP	Action on positive directional pulses (‡). PNP systems are pulled down to GND.
[1]	NPN	Action on negative directional pulses (‡). NPN systems are pulled up to + 24 V, internally in the filter.

NOTE

Once this parameter has been changed, it must be activated by performing a power cycle.

This parameter cannot be adjusted while the motor is running.

5-01 Terminal 27 Mode		
Option:	Function:	
[0] *	Input	Defines terminal 27 as a digital input.
[1]	Output	Defines terminal 27 as a digital output.

5-02 Terminal 29 Mode		
Option:	Function:	
[0] *	Input	Defines terminal 29 as a digital input.
[1]	Output	Defines terminal 29 as a digital output.

This parameter is available for FC 302 only.

6.2.10 5-1* Digital Inputs

Parameters for configuring the input functions for the input terminals.

The digital inputs are used for selecting various functions in the filter. All digital inputs can be set to the following functions:

Digital input function	Select	Terminal
No operation	[0]	All *term 32, 33
Reset	[1]	All
Stop inverse	[6]	All
Start	[8]	All *term 18
Latched start	[9]	All
Set-up select bit 0	[23]	All
Set-up select bit 1	[24]	All
Precise stop inverse	[26]	18, 19
Precises start, stop	[27]	18, 19
Pulse input Time Based	[32]	29, 33
Ramp bit 0	[34]	All
Mains failure inverse	[36]	All
Latched precise start	[40]	18, 19
Digipot Hoist	[58]	All

Functions dedicated to only one digital input are stated in the associated parameter.

5-10 Terminal 18 Digital Input		
Standard terminals are 18, 19, 27, 29, 32 and 33. MCB 101 terminals are X30/2, X30/3 and X30/4. Terminal 29 functions as an output only in FC 302.		
Option:	Function:	
[0]	No operation	No reaction to signals transmitted to the terminal.
[1]	Reset	Resets filter after a TRIP/ALARM. Not all alarms can be reset.
[6]	Stop inverse	Stop Inverted function. Generates a stop function when the selected terminal goes from logical level '1' to '0'. The stop is performed according to the selected ramp time (par. 3-42 <i>Ramp 1 Ramp Down Time</i> ,

5-10 Terminal 18 Digital Input		
<p>Standard terminals are 18, 19, 27, 29, 32 and 33. MCB 101 terminals are X30/2, X30/3 and X30/4.</p> <p>Terminal 29 functions as an output only in FC 302.</p> <p>Option: Function:</p>		
		<p>par. 3-52 <i>Ramp 2 Ramp down Time</i>, par. 3-62 <i>Ramp 3 Ramp down Time</i>, par. 3-72 <i>Ramp 4 Ramp Down Time</i>).</p> <p>NOTE When the unit is at the torque limit and has received a stop command, it may not stop by itself. To ensure that the unit stops, configure a digital output to <i>Torque limit & stop</i> [27] and connect this digital output to a digital input that is configured as coast.</p>
[8] *	Start	(Default Digital input 18): Select start for a start/stop command. Logic '1' = start, logic '0' = stop.
[9]	Latched Start	The motor starts, if a pulse is applied for min. 2 ms. The motor stops when Stop inverse is activated.
[23]	Set-up select bit 0	Select Set-up select bit 0 or Select Set-up select bit 1 to select one of the four set-ups. Set par. 0-10 <i>Active Set-up</i> to Multi Set-up.
[24]	Set-up select bit 1	(Default Digital input 32): Same as Set-up select bit 0 [23].
[32]	Master cmd pulse in	<p>Time based pulse input measures the duration between flanks. This gives a higher resolution at lower frequencies, but is not as precise at higher frequencies. This principle has a cut-off frequency which makes it unsuited for encoders with very low resolutions (e.g. 30 ppr) at low speeds.</p> <div style="border: 1px solid black; padding: 5px; margin: 10px 0;"> <p style="text-align: center;">a: very low encoder resolution b: standard encoder resolution</p> </div> <div style="margin-top: 10px;"> </div>
[99]	Follower AF #1 Run Feedback	

5-10 Terminal 18 Digital Input		
<p>Standard terminals are 18, 19, 27, 29, 32 and 33. MCB 101 terminals are X30/2, X30/3 and X30/4.</p> <p>Terminal 29 functions as an output only in FC 302.</p> <p>Option: Function:</p>		
[100]	Follower AF #2 Run Feedback	

5-11 Terminal 19 Digital Input		
<p>Option: Function:</p>		
[10] *	Reversing	Functions are described under 5-1* <i>Digital Inputs</i>

5-12 Terminal 27 Digital Input		
<p>Option: Function:</p>		
[2] *	Coast inverse	Functions are described under 5-1* <i>Digital Inputs</i>

5-13 Terminal 29 Digital Input		
<p>Option: Function:</p>		
		Select the function from the available digital input range and the additional options [60], [61], [63] and [64]. Counters are used in Smart Logic Control functions. This parameter is available for FC 302 only.
[14] *	Jog	Functions are described under 5-1* <i>Digital Inputs</i>

5-14 Terminal 32 Digital Input		
<p>Option: Function:</p>		
		Select the function from the available digital input range and the additional options [60], [61], [63] and [64]. Counters are used in Smart Logic Control functions.
[0] *	No operation	Functions are described under 5-1* <i>Digital Inputs</i>

5-15 Terminal 33 Digital Input		
<p>Option: Function:</p>		
		Select the function from the available digital input range and the additional options [60], [61], [63] and [64]. Counters are used in Smart Logic Control functions.
[0] *	No operation	Functions are described under 5-1* <i>Digital Inputs</i>

5-16 Terminal X30/2 Digital Input		
<p>Option: Function:</p>		
[0] *	No operation	Functions are described under 5-1* <i>Digital Inputs</i>

5-17 Terminal X30/3 Digital Input		
<p>Option: Function:</p>		
[0] *	No operation	Functions are described under 5-1* <i>Digital Inputs</i>

5-18 Terminal X30/4 Digital Input

Option:	Function:
[0] *	No operation Functions are described under 5-1* <i>Digital Inputs</i>

5-19 Terminal 37 Safe Stop

Option:	Function:
[1] *	Safe Stop Alarm Coasts frequency converter when safe stop is activated. Manual reset from LCP, digital input or fieldbus.
[3]	Safe Stop Warning Coasts frequency converter when safe stop is activated (T-37 off). When safe stop circuit is reestablished, the frequency converter will continue without manual reset.
[4]	PTC 1 Alarm Coasts frequency converter when safe stop is activated. Manual reset from LCP, digital input or fieldbus. Choice 4 is only available when the MCB 112 PTC Thermistor Card is connected.
[5]	PTC 1 Warning Coasts frequency converter when safe stop is activated (T-37 off). When safe stop circuit is reestablished, the frequency converter will continue without manual reset, unless a Digital Input set to PTC Card 1 [80] is still enabled. Choice 5 is only available when the MCB 112 PTC Thermistor Card is connected.
[6]	PTC 1 & Relay A This choice is used when the PTC option is gated together with a Stop button through a Safety relay to T-37. Coasts frequency converter when safe stop is activated. Manual reset from

5-19 Terminal 37 Safe Stop

Option:	Function:
	LCP, digital input or fieldbus. Choice 6 is only available when the MCB 112 PTC Thermistor Card is connected.
[7]	PTC 1 & Relay W This choice is used when the PTC option is gated together with a Stop button through a Safety relay to T-37. Coasts frequency converter when safe stop is activated (T-37 off). When safe stop circuit is reestablished, the frequency converter will continue without manual reset, unless a Digital Input set to PTC Card 1 [80] is (still) enabled. Choice 7 is only available when the MCB 112 PTC Thermistor Card is connected.
[8]	PTC 1 & Relay A/W This choice makes it possible to use a combination of Alarm and Warning. Choice 8 is only available when the MCB 112 PTC Thermistor Card is connected.
[9]	PTC 1 & Relay W/A This choice makes it possible to use a combination of Alarm and Warning. Choice 9 is only available when the MCB 112 PTC Thermistor Card is connected.

Choices 4 - 9 are only available when the MCB 112 PTC Thermistor Card is connected.

NOTE
When Auto Reset/ Warning is selected the frequency converter opens up for automatic restart.

Overview of functions, alarms and warnings

Function	No.	PTC	Relay
No Function	[0]	-	-
Safe Stop Alarm	[1]*	-	Safe Stop [A68]
Safe Stop Warning	[3]	-	Safe Stop [W68]
PTC 1 Alarm	[4]	PTC 1 Safe Stop [A71]	-
PTC 1 Warning	[5]	PTC 1 Safe Stop [W71]	-
PTC 1 & Relay A	[6]	PTC 1 Safe Stop [A71]	Safe Stop [A68]
PTC 1 & Relay W	[7]	PTC 1 Safe Stop [W71]	Safe Stop [W68]
PTC 1 & Relay A/W	[8]	PTC 1 Safe Stop [A71]	Safe Stop [W68]
PTC 1 & Relay W/A	[9]	PTC 1 Safe Stop [W71]	Safe Stop [A68]

W means warning and A means alarm. For further information, see Alarms and Warnings in section *Troubleshooting* in the Design Guide or the Operating Instructions
A dangerous failure related to Safe Stop will give Alarm: Dangerous Failure [A72].

Please refer to the section *Description of Alarm Word, Warning Word and extended Status Word* in the chapter *Troubleshooting*.

6.2.11 5-3* Digital Outputs

Parameters for configuring the output functions for the output terminals. The 2 solid-state digital outputs are common for terminals 27 and 29. Set the I/O function for terminal 27 in par. 5-01 *Terminal 27 Mode*, and set the I/O function for terminal 29 in par. 5-02 *Terminal 29 Mode*. These parameters cannot be adjusted while the unit is running.

5-30 Terminal 27 Digital Output		
Option:	Function:	
[0]	No operation	Default for all digital outputs and relay outputs
[1]	Control ready	The control card is ready. E.g.: Feedback from a drive where the control is supplied by an external 24 V (MCB 107) and the main power to drive is not detected.
[2]	Unit ready	The frequency converter is ready for operation and applies a supply signal on the control board.
[4]	Enable / no warning	Ready for operation. No start or stop command is been given (start/disable). No warnings are active.
[5]	Running	Motor is running and shaft torque present.
[9]	Alarm	An alarm activates the output. There are no warnings.
[10]	Alarm or warning	An alarm or a warning activates the output.
[12]	Current limit	The motor current is outside the range set in par. 4-18 <i>Current Limit</i> .
[21]	Thermal warning	The thermal warning turns on when the temperature exceeds the limit in the motor, the frequency converter, the brake resistor, or the thermistor.
[22]	Ready, no thermal W	Frequency converter is ready for operation and there is no over-temperature warning.
[24]	Ready, voltage OK	Frequency converter is ready for operation and the mains voltage is within the specified voltage range (see <i>General Specifications</i> section in the Designn Guide).
[26]	Bus OK	Active communication (no time-out) via the serial communication port.
[55]	Pulse output	
[122]	No alarm	
[125]	Hand mode	Output is high when the unit is in Hand on mode (as indicated by the LED light above [Hand on]).
[126]	Auto mode	

5-31 Terminal 29 Digital Output

Option:	Function:	
[0] *	No operation	Functions are described under 5-3* <i>Digital Outputs</i> This parameter only applies to FC 302

6.2.12 5-4* Relays

Parameters for configuring the timing and the output functions for the relays.

5-40 Function Relay		
Option:	Function:	
[0]	No operation	
[128]	SC contactor	
[129]	Mains contactor	

5-41 On Delay, Relay		
Array [9], (Relay 1 [0], Relay 2 [1], Relay 3 [2], Relay 4 [3], Relay 5 [4], Relay 6 [5], Relay 7 [6], Relay 8 [7], Relay 9 [8])		
Range:	Function:	
0.01 s*	[0.01 - 600.00 s]	Enter the delay of the relay cut-in time. Select one of available mechanical relays and MCB 105 in an array function. See par. 5-40 <i>Function Relay</i> . Relay 3-6 are included in MCB 113.

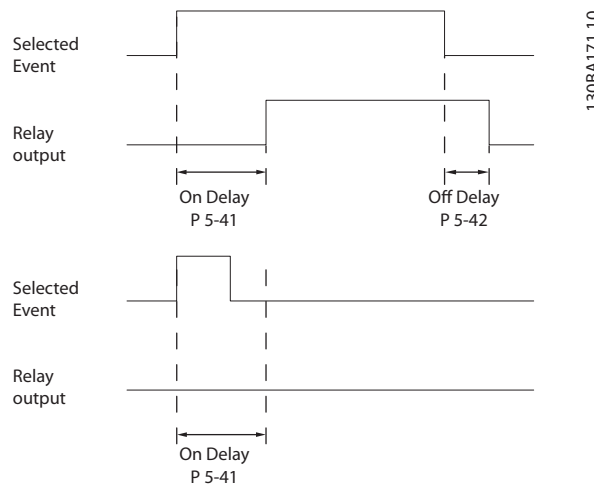

5-42 Off Delay, Relay		
Array [9] (Relay 1 [0], Relay 2 [1], Relay 3 [2], Relay 4 [3], Relay 5 [4], Relay 6 [5], Relay 7 [6], Relay 8 [7], Relay 9 [8])		
Range:	Function:	
0.01 s*	[0.01 - 600.00 s]	Enter the delay of the relay cut-out time. Select one of available mechanical relays and MCB 105 in an array function. See par. 5-40 <i>Function Relay</i> .

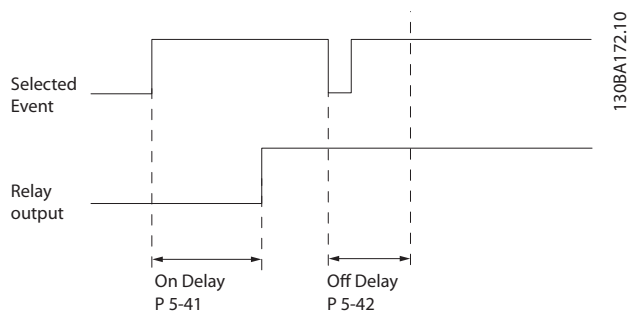

If the selected Event condition changes before the on- or off delay timer expires, the relay output is unaffected.

6.2.13 8-0* General Settings

8-01 Control Site		
Option:	Function:	
	The setting in this parameter overrides the settings in par. 8-50 <i>Coasting Select</i> to par. 8-56 <i>Preset Reference Select</i> .	
[0] *	Digital and ctrl.word	Control by using both digital input and control word.
[1]	Digital only	Control by using digital inputs only.
[2]	Controlword only	Control by using control word only.

8-02 Control Word Source		
<p>Select the source of the control word: one of two serial interfaces or four installed options. During initial power-up, the frequency converter automatically sets this parameter to <i>Option A</i> [3] if it detects a valid fieldbus option installed in slot A. If the option is removed, the frequency converter detects a change in the configuration, sets par. 8-02 <i>Control Word Source</i> back to default setting <i>FC RS-485</i>, and the frequency converter then trips. If an option is installed after initial power-up, the setting of par. 8-02 <i>Control Word Source</i> will not change but the frequency converter will trip and display: <i>Alarm 67 Option Changed</i>.</p> <p>This parameter cannot be adjusted while the motor is running.</p>		
Option:	Function:	
[0]	None	
[1]	FC RS485	
[2]	FC USB	
[3] *	Option A	
[4]	Option B	
[5]	Option C0	
[6]	Option C1	
[30]	External Can	

8-03 Control Word Timeout Time		
Range:	Function:	
1.0 s*	[Application dependant]	Enter the maximum time expected to pass between the reception of two consecutive telegrams. If this time is exceeded, it indicates that the serial communication has stopped. The function selected in par. 8-04 <i>Control Word Timeout Function</i> will then be carried out. The time-out counter is triggered by a valid control word.

8-04 Control Word Timeout Function		
<p>Select the time-out function. The time-out function activates when the control word fails to be updated within the time period specified in par. 8-03 <i>Control Word Timeout Time</i>.</p>		
Option:	Function:	
[0] *	Off	Resumes control via serial bus (Fieldbus or standard) using the most recent control word.
[1]	Freeze output	Freezes output frequency until communication resumes.
[2]	Stop	Stops with auto restart when communication resumes.
[3]	Jogging	Runs the motor at JOG frequency until communication resumes.
[4]	Max. speed	Runs the motor at maximum frequency until communication resumes.
[5]	Stop and trip	Stops the motor, then resets the frequency converter in order to restart: via the fieldbus, via the reset button on the LCP or via a digital input.
[7]	Select setup 1	Changes the set-up upon reestablishment of communication following a control word time-out. If communication resumes causing the time-out situation to disappear, par. 8-05 <i>End-of-Timeout Function</i> defines whether to resume the set-up used before the time-out or to retain the set-up endorsed by the time-out function.
[8]	Select setup 2	See [7] <i>Select setup 1</i>
[9]	Select setup 3	See [7] <i>Select setup 1</i>
[10]	Select setup 4	See [7] <i>Select setup 1</i>

NOTE

The following configuration is required in order to change the set-up after a time-out:
Set par. 0-10 *Active Set-up* to [9] *Multi set-up* and select the relevant link in par. 0-12 *This Set-up Linked to*.

8-05 End-of-Timeout Function		
Option:	Function:	
		Select the action after receiving a valid control word following a time-out. This parameter is active only when par. 8-04 <i>Control Timeout Function</i> is set to [Set-up 1-4].
[0]	Hold set-up	Retains the set-up selected in par. 8-04 <i>Control Timeout Function</i> and displays a warning, until par. 8-06 <i>Reset Control Timeout</i> toggles. Then the unit resumes its original set-up.
[1] *	Resume set-up	Resumes the set-up active prior to the time-out.

8-06 Reset Control Word Timeout		
This parameter is active only when <i>Hold set-up</i> [0] has been selected in par. 8-05 <i>End-of-Timeout Function</i> .		
Option:	Function:	
[0] *	Do not reset	Retains the set-up specified in par. 8-04 <i>Control Word Timeout Function</i> , following a control word time-out.
[1]	Do reset	Returns the unit to the original set-up following a control word time-out. The unit performs the reset and then immediately reverts to the <i>Do not reset</i> [0] setting

6.2.14 8-3* FC Port Settings

8-30 Protocol		
Option:	Function:	
[0] *	FC	
[1]	FC MC	Select the protocol for the FC (standard) port.
[2]	Modbus RTU	

8-31 Address		
Range:	Function:	
Application dependent*	[Application dependant]	Enter the address for the FC (standard) port. Valid range: 1 - 126.

8-32 FC Port Baud Rate		
Option:	Function:	
[0]	2400 Baud	Baud rate selection for the FC (standard) port.
[1]	4800 Baud	
[2] *	9600 Baud	
[3]	19200 Baud	
[4]	38400 Baud	
[5]	57600 Baud	
[6]	76800 Baud	
[7]	115200 Baud	

8-35 Minimum Response Delay		
Range:	Function:	
10 ms*	[Application dependant]	Specify the minimum delay time between receiving a request and transmitting a response. This is used for overcoming modem turnaround delays.

8-36 Max Response Delay		
Range:	Function:	
Application dependent*	[Application dependant]	Specify the maximum permissible delay time between transmitting a request and receiving a response. Exceeding this delay time will cause control word time-out.

8-37 Max Inter-Char Delay		
Range:	Function:	
Application dependent*	[Application dependant]	Specify the maximum permissible time interval between receipt of two bytes. This parameter activates time-out if transmission is interrupted. This parameter is active only when par. 8-30 <i>Protocol</i> is set to <i>FC MC</i> [1] protocol.

8-53 Start Select		
Option:	Function:	
		Select control of the unit start function via the terminals (digital input) and/or via the fieldbus.
[0]	Digital input	Activates Start command via a digital input.
[1]	Bus	Activates Start command via the serial communication port or fieldbus option.
[2]	Logic AND	Activates Start command via the fieldbus/serial communication port, AND additionally via one of the digital inputs.
[3] *	Logic OR	Activates Start command via the fieldbus/serial communication port OR via one of the digital inputs.

NOTE

This parameter is active only when par. 8-01 *Control Site* is set to [0] *Digital and control word*.

8-55 Set-up Select		
Option:	Function:	
		Select control of the unit set-up selection via the terminals (digital input) and/or via the fieldbus.
[0]	Digital input	Activates the set-up selection via a digital input.
[1]	Bus	Activates the set-up selection via the serial communication port or fieldbus option.
[2]	Logic AND	Activates the set-up selection via the fieldbus/serial communication port, AND additionally via one of the digital inputs.
[3] *	Logic OR	Activate the set-up selection via the fieldbus/serial communication port OR via one of the digital inputs.

NOTE
This parameter is active only when par. 8-01 *Control Site* is set to [0] *Digital and control word*.

6.2.15 14-2* Trip Reset

Parameters for configuring auto reset handling, special trip handling and control card self test or initialisation.

14-20 Reset Mode		
Option:	Function:	
		Select the reset function after tripping. Once reset, the unit can be restarted.
[0] *	Manual reset	Select <i>Manual reset</i> [0], to perform a reset via [RESET] or via the digital inputs.
[1]	Automatic reset x 1	Select <i>Automatic reset x 1...x20</i> [1]-[12] to perform between one and twenty automatic resets after tripping.
[2]	Automatic reset x 2	
[3]	Automatic reset x 3	
[4]	Automatic reset x 4	
[5]	Automatic reset x 5	
[6]	Automatic reset x 6	
[7]	Automatic reset x 7	
[8]	Automatic reset x 8	
[9]	Automatic reset x 9	
[10]	Automatic reset x 10	
[11]	Automatic reset x 15	
[12]	Automatic reset x 20	
[13]	Infinite auto reset	Select <i>Infinite Automatic Reset</i> [13] for continuous resetting after tripping.
[14]	Reset at power-up	

NOTE

The motor may start without warning. If the specified number of AUTOMATIC RESETs is reached within 10 minutes, the unit enters Manual reset [0] mode. After the Manual reset is performed, the setting of par. 14-20 *Reset Mode* reverts to the original selection. If the number of automatic resets is not reached within 10 minutes, or when a Manual reset is performed, the internal AUTOMATIC RESET counter returns to zero.

NOTE

Automatic reset will also be active for resetting safe stop function in firmware version < 4.3x.

14-21 Automatic Restart Time		
Range:	Function:	
10 s*	[0 - 600 s]	Enter the time interval from trip to start of the automatic reset function. This parameter is active when par. 14-20 <i>Reset Mode</i> is set to <i>Automatic reset</i> [1] - [13].

14-22 Operation Mode		
Option:	Function:	
		Use this parameter to specify normal operation; to perform tests; or to initialise all parameters except par. 15-03 <i>Power Up's</i> , par. 15-04 <i>Over Temp's</i> and par. 15-05 <i>Over Volt's</i> . This function is active only when the power is cycled to the unit. Select <i>Normal operation</i> [0] for normal operation of the unit. Select <i>Control card test</i> [1] to test the analog and digital inputs and outputs and the +10 V control voltage. The test requires a test connector with internal connections. Use the following procedure for the control card test:
		<ol style="list-style-type: none"> 1. Select <i>Control card test</i> [1]. 2. Disconnect the mains supply and wait for the light in the display to go out. 3. Set switches S201 (A53) and S202 (A54) = 'ON' / I. 4. Insert the test plug (see below). 5. Connect to mains supply. 6. Carry out various tests. 7. The results are displayed on the LCP and the unit moves into an infinite loop. 8. Par. 14-22 <i>Operation Mode</i> is automatically set to Normal operation. Carry out a power cycle to start up in

14-22 Operation Mode	
Option:	Function:
	<p>Normal operation after a control card test.</p> <p>If the test is OK: LCP read-out: Control Card OK. Disconnect the mains supply and remove the test plug. The green LED on the Control Card will light up.</p> <p>If the test fails: LCP read-out: Control Card I/O failure. Replace the unit or Control card. The red LED on the Control Card is turned on. Test plugs (connect the following terminals to each other): 18 - 27 - 32; 19 - 29 - 33; 42 - 53 - 54</p> <p>Select <i>Initialization</i> [2] to reset all parameter values to default settings, except for par. 15-03 <i>Power Up's</i>, par. 15-04 <i>Over Temp's</i>, and par. 15-05 <i>Over Volt's</i>. The unit will reset during the next power-up. Par. 14-22 <i>Operation Mode</i> will also revert to the default setting <i>Normal operation</i> [0].</p>
[0] *	Normal operation
[1]	Control card test
[2]	Initialisation
[3]	Boot mode

14-29 Service Code	
Range:	Function:
0*	[-2147483647 - 2147483647] For internal service only.

14-50 RFI Filter	
Option:	Function:
[0]	Off Select <i>Off</i> [0] only if the unit is fed by an isolated mains source (IT mains). In this mode, the internal RFI filter capacitors between chassis and the mains RFI filter circuit are cut-out to reduce the ground capacity currents.
[1] *	On Select <i>On</i> [1] to ensure that the unit complies with EMC standards.

14-54 Bus Partner	
Range:	Function:
1*	[0 - 126]

Parameter group containing filter information such as operating data, hardware configuration and software versions.

6.2.16 15-0* Operating Data

15-00 Operating Hours	
Range:	Function:
0 h*	[0 - 2147483647 h] View how many hours the unit has run. The value is saved when the unit is turned off.

15-01 Running Hours	
Range:	Function:
0 h*	[0 - 2147483647 h] View how many hours the motor has run. Reset the counter in par. 15-07 <i>Reset Running Hours Counter</i> . The value is saved when the unit is turned off.

15-03 Power Up's	
Range:	Function:
0 N/A*	[0 - 2147483647 N/A] View the number of times the unit has been powered up.

15-04 Over Temp's	
Range:	Function:
0 N/A*	[0 - 65535 N/A] View the number of unit temperature faults which have occurred.

15-05 Over Volt's	
Range:	Function:
0 N/A*	[0 - 65535 N/A] View the number of unit overvoltages which have occurred.

15-07 Reset Running Hours Counter		
Option:	Function:	
[0] *	Do not reset	
[1]	Reset counter	Select <i>Reset</i> [1] and press [OK] to reset the Running Hours counter to zero (see par. 15-01 <i>Running Hours</i>). This parameter cannot be selected via the serial port, RS-485. Select <i>Do not reset</i> [0] if no reset of the Running Hours counter is desired.

15-12 Trigger Event		
Select the trigger event. When the trigger event occurs, a window is applied to freeze the log. The log will then retain a specified percentage of samples before the occurrence of the trigger event (par. 15-14 <i>Samples Before Trigger</i>).		
Option:	Function:	
[21]	Alarm (trip lock)	
[33]	Digital input DI18	
[34]	Digital input DI19	
[35]	Digital input DI27	
[36]	Digital input DI29	
[37]	Digital input DI32	
[38]	Digital input DI33	

6.2.17 15-1* Data Log Settings

The Data Log enables continuous logging of up to 4 data sources (par. 15-10 *Logging Source*) at individual rates (par. 15-11 *Logging Interval*). A trigger event (par. 15-12 *Trigger Event*) and window (par. 15-14 *Samples Before Trigger*) are used to start and stop the logging conditionally.

15-10 Logging Source		
Array [4]		
Option:	Function:	
		Select which variables are to be logged.
[0] *	None	
[1600]	Control Word	
[1603]	Status Word	
[1630]	DC Link Voltage	
[1634]	Heatsink Temp.	
[1635]	Inverter Thermal	
[1660]	Digital Input	
[1666]	Digital Output [bin]	
[1690]	Alarm Word	
[1692]	Warning Word	
[1694]	Ext. Status Word	

15-13 Logging Mode		
Option:	Function:	
[0] *	Log always	Select <i>Log always</i> [0] for continuous logging.
[1]	Log once on trigger	Select <i>Log once on trigger</i> [1] to conditionally start and stop logging using par. 15-12 <i>Trigger Event</i> and par. 15-14 <i>Samples Before Trigger</i> .

15-14 Samples Before Trigger		
Range:	Function:	
50*	[0 - 100]	Enter the percentage of all samples prior to a trigger event which are to be retained in the log. See also par. 15-12 <i>Trigger Event</i> and par. 15-13 <i>Logging Mode</i> .

15-11 Logging Interval		
Range:	Function:	
Application dependent*	[Application dependant]	Enter the interval in milliseconds between each sampling of the variables to be logged.

15-12 Trigger Event		
Select the trigger event. When the trigger event occurs, a window is applied to freeze the log. The log will then retain a specified percentage of samples before the occurrence of the trigger event (par. 15-14 <i>Samples Before Trigger</i>).		
Option:	Function:	
[0] *	False	
[1]	True	
[2]	Running	
[6]	Current limit	
[16]	Thermal warning	
[19]	Warning	
[20]	Alarm (trip)	

6.2.18 15-2* Historic Log

View up to 50 logged data items via the array parameters in this par. group. For all parameters in the group, [0] is the most recent data and [49] the oldest data. Data is logged every time an event occurs (not to be confused with SLC events). Events in this context are defined as a change in one of the following areas:

1. Digital input
2. Digital outputs (not monitored in this SW release)
3. Warning word
4. Alarm word
5. Status word
6. Control word
7. Extended status word

Events are logged with value, and time stamp in msec. The time interval between two events depends on how often events occur (maximum once every scan time). Data logging is continuous but if an alarm occurs, the log is saved and the values can be viewed on the display. This feature is useful, for example when carrying out service following a trip. View the

historic log contained in this parameter via the serial communication port or via the display.

15-20 Historic Log: Event		
Array [50]		
Range:	Function:	
0 N/A* [0 - 255 N/A]	View the event type of the logged events.	

15-21 Historic Log: Value		
Array [50]		
Range:	Function:	
0 N/A* [0 - 2147483647 N/A]	View the value of the logged event. Interpret the event values according to this table:	
	Digital input	Decimal value. See par. 16-60 <i>Digital Input</i> for description after converting to binary value.
	Digital output (not monitored in this SW release)	Decimal value. See par. 16-66 <i>Digital Output [bin]</i> for description after converting to binary value.
	Warning word	Decimal value. See par. 16-92 <i>Warning Word</i> for description.
	Alarm word	Decimal value. See par. 16-90 <i>Alarm Word</i> for description.
	Status word	Decimal value. See par. 16-03 <i>Status Word</i> for description after converting to binary value.
	Control word	Decimal value. See par. 16-00 <i>Control Word</i> for description.
	Extended status word	Decimal value. See par. 16-94 <i>Ext. Status Word</i> for description.

15-22 Historic Log: Time		
Array [50]		
Range:	Function:	
0 ms* [0 - 2147483647 ms]	View the time at which the logged event occurred. Time is measured in ms since unit start. The max. value corresponds to approx. 24 days which means that the count will restart at zero after this time period.	

6.2.19 15-3* Alarm Log

Parameters in this group are array parameters, where up to 10 fault logs can be viewed. [0] is the most recent logged data, and [9] the oldest. Error codes, values, and time stamp can be viewed for all logged data.

15-30 Fault Log: Error Code		
Array [10]		
Range:	Function:	
0* [0 - 255]	View the error code and look up its meaning in the <i>Troubleshooting</i> chapter of the FC 300 Design Guide.	

15-31 Alarm Log: Value		
Array [10]		
Range:	Function:	
0 N/A* [-32767 - 32767 N/A]	View an extra description of the error. This parameter is mostly used in combination with alarm 38 'internal fault'.	

15-32 Alarm Log: Time		
Array [10]		
Range:	Function:	
0 s* [0 - 2147483647 s]	View the time when the logged event occurred. Time is measured in seconds from unit start-up.	

6.2.20 15-4* Unit Identification

Parameters containing read only information about the hardware and software configuration of the active filter.

15-40 FC Type		
Range:	Function:	
0* [0 - 0]	View the FC type. The read-out is identical to the FC 300 Series power field of the type code definition, characters 1-6.	

15-41 Power Section		
Range:	Function:	
0* [0 - 0]	View the FC type. The read-out is identical to the FC 300 Series power field of the type code definition, characters 7-10.	

15-42 Voltage		
Range:	Function:	
0* [0 - 0]	View the FC type. The read-out is identical to the FC 300 Series power field of the type code definition, characters 11-12.	

15-43 Software Version		
Range:	Function:	
0 N/A*	[0 - 0 N/A]	View the combined SW version (or 'package version') consisting of power SW and control SW.

15-44 Ordered Typecode String		
Range:	Function:	
0 N/A*	[0 - 0 N/A]	View the type code string used for re-ordering the active filter in its original configuration.

15-45 Actual Typecode String		
Range:	Function:	
0 N/A*	[0 - 0 N/A]	View the actual type code string.

15-46 Unit Ordering No		
Range:	Function:	
0 N/A*	[0 - 0 N/A]	View the 8-digit ordering number used for re-ordering the active filter in its original configuration.

15-47 Power Card Ordering No		
Range:	Function:	
0 N/A*	[0 - 0 N/A]	View the power card ordering number.

15-48 LCP Id No		
Range:	Function:	
0 N/A*	[0 - 0 N/A]	View the LCP ID number.

15-49 SW ID Control Card		
Range:	Function:	
0 N/A*	[0 - 0 N/A]	View the control card software version number.

15-50 SW ID Power Card		
Range:	Function:	
0 N/A*	[0 - 0 N/A]	View the power card software version number.

15-51 Unit Serial Number		
Range:	Function:	
0 N/A*	[0 - 0 N/A]	View the active filter serial number.

15-53 Power Card Serial Number		
Range:	Function:	
0 N/A*	[0 - 0 N/A]	View the power card serial number.

6.2.21 15-6* Option Ident.

This read-only par. group contains information about the hardware and software configuration of the options installed in slots A, B C0 and C1.

15-60 Option Mounted		
Range:	Function:	
0 N/A*	[0 - 0 N/A]	View the installed option type.

15-61 Option SW Version		
Range:	Function:	
0 N/A*	[0 - 0 N/A]	View the installed option software version.

15-62 Option Ordering No		
Range:	Function:	
0 N/A*	[0 - 0 N/A]	Shows the ordering number for the installed options.

15-63 Option Serial No		
Range:	Function:	
0 N/A*	[0 - 0 N/A]	View the installed option serial number.

15-70 Option in Slot A		
Range:	Function:	
0 N/A*	[0 - 0 N/A]	View the type code string for the option installed in slot A, and a translation of the type code string. E.g. for type code string 'AX' the translation is 'No option'.

15-71 Slot A Option SW Version		
Range:	Function:	
0 N/A*	[0 - 0 N/A]	View the software version for the option installed in slot A.

15-72 Option in Slot B		
Range:	Function:	
0 N/A*	[0 - 0 N/A]	View the type code string for the option installed in slot B, and a translation of the type code string. E.g. for type code string 'BX' the translation is 'No option'.

15-73 Slot B Option SW Version		
Range:	Function:	
0 N/A*	[0 - 0 N/A]	View the software version for the option installed in slot B.

15-74 Option in Slot C0		
Range:	Function:	
0 N/A*	[0 - 0 N/A]	View the type code string for the option installed in slot C, and a translation of the type code string. E.g. for type code string 'CXXX' the translation is 'No option'.

15-75 Slot C0 Option SW Version		
Range:	Function:	
0 N/A*	[0 - 0 N/A]	View the software version for the option installed in slot C.

15-76 Option in Slot C1		
Range:	Function:	
0 N/A*	[0 - 0 N/A]	Shows the typecode string for the options (CXXXX if no option) and the translation i.e. >No option<.

15-77 Slot C1 Option SW Version		
Range:	Function:	
0 N/A*	[0 - 0 N/A]	Software version for the installed option in option slot C.

6.2.22 15-9* Parameter Info

15-92 Defined Parameters		
Array [1000]		
Range:	Function:	
0 N/A*	[0 - 9999 N/A]	View a list of all defined parameters in the active filter. The list ends with 0.

15-93 Modified Parameters		
Array [1000]		
Range:	Function:	
0 N/A*	[0 - 9999 N/A]	View a list of the parameters that have been changed from their default setting. The list ends with 0. Changes may not be visible until up to 30 seconds after implementation.

15-98 Unit Identification		
Range:	Function:	
0 N/A*	[0 - 0 N/A]	

15-99 Parameter Metadata		
Array [30]		
Range:	Function:	
0*	[0 - 9999]	This parameter contains data used by the MCTæ10 software tool.

6.2.23 16-0* General Status

16-00 Control Word		
Range:	Function:	
0 N/A*	[0 - 65535 N/A]	View the Control word sent from the unit via the serial communication port in hex code.

16-03 Status Word		
Range:	Function:	
0 N/A*	[0 - 65535 N/A]	View the Status word sent from the unit via the serial communication port in hex code.

6.2.24 16-3* AF Status

16-30 DC Link Voltage		
Range:	Function:	
0 V*	[0 - 10000 V]	View a measured value. The value is filtered with an 30 ms time constant.

16-34 Heatsink Temp.		
Range:	Function:	
0 C*	[0 - 255 C]	View the heatsink temperature. The cut-out limit is 90 ± 5 °C, and the motor cuts back in at 60 ± 5 °C.

16-35 Inverter Thermal		
Range:	Function:	
0 %*	[0 - 100 %]	View the percentage load on the inverter.

16-36 Inv. Nom. Current		
Range:	Function:	
Application dependent*	[0.01 - 10000.00 A]	View the inverter nominal current, which should match the nameplate data on the connected motor. The data are used for calculation of torque, motor protection, etc.

16-37 Inv. Max. Current		
Range:	Function:	
Application dependent*	[0.01 - 10000.00 A]	View the inverter maximum current, which should match the nameplate data on the connected motor. The data are used for calculation of torque, motor protection, etc.

16-39 Control Card Temp.		
Range:	Function:	
0 C*	[0 - 100 C]	View the temperature on the control card, stated in °C.

16-40 Logging Buffer Full		
Option:	Function:	
	View whether the logging buffer is full (see par. group 15-1*). The logging buffer will never be full when par. 15-13 <i>Logging Mode</i> is set to <i>Log always</i> [0].	
[0] *	No	
[1]	Yes	

16-49 Current Fault Source		
Range:	Function:	
0*	[0 - 8]	Value indicates source of current faults including short circuit, over current, and phase imbalance (from left): 1-4 Inverter 5-8 Rectifier 0 No fault recorded

16-71 Relay Output [bin]		
Range:	Function:	
		Readout choice (Par. 16-71): Relay output (bin): 0 0 0 0 0 bin OptionB card relay 09 OptionB card relay 08 OptionB card relay 07 Power card relay 02 Power card relay 01

6.2.25 16-6* Inputs and Outputs

16-60 Digital Input																								
Range:	Function:																							
0 N/ A*	[0 - 1023 N/A]	View the signal states from the active digital inputs. Example: Input 18 corresponds to bit no. 5, '0' = no signal, '1' = connected signal. Bit 6 works in the opposite way, on = '0', off = '1' (safe stop input).																						
		<table border="1"> <tr><td>Bit 0</td><td>Digital input term. 33</td></tr> <tr><td>Bit 1</td><td>Digital input term. 32</td></tr> <tr><td>Bit 2</td><td>Digital input term. 29</td></tr> <tr><td>Bit 3</td><td>Digital input term. 27</td></tr> <tr><td>Bit 4</td><td>Digital input term. 19</td></tr> <tr><td>Bit 5</td><td>Digital input term. 18</td></tr> <tr><td>Bit 6</td><td>Digital input term. 37</td></tr> <tr><td>Bit 7</td><td>Digital input GP I/O term. X30/4</td></tr> <tr><td>Bit 8</td><td>Digital input GP I/O term. X30/3</td></tr> <tr><td>Bit 9</td><td>Digital input GP I/O term. X30/2</td></tr> <tr><td>Bit 10-63</td><td>Reserved for future terminals</td></tr> </table> 	Bit 0	Digital input term. 33	Bit 1	Digital input term. 32	Bit 2	Digital input term. 29	Bit 3	Digital input term. 27	Bit 4	Digital input term. 19	Bit 5	Digital input term. 18	Bit 6	Digital input term. 37	Bit 7	Digital input GP I/O term. X30/4	Bit 8	Digital input GP I/O term. X30/3	Bit 9	Digital input GP I/O term. X30/2	Bit 10-63	Reserved for future terminals
Bit 0	Digital input term. 33																							
Bit 1	Digital input term. 32																							
Bit 2	Digital input term. 29																							
Bit 3	Digital input term. 27																							
Bit 4	Digital input term. 19																							
Bit 5	Digital input term. 18																							
Bit 6	Digital input term. 37																							
Bit 7	Digital input GP I/O term. X30/4																							
Bit 8	Digital input GP I/O term. X30/3																							
Bit 9	Digital input GP I/O term. X30/2																							
Bit 10-63	Reserved for future terminals																							

6.2.26 16-8* Fieldbus & FC Port

Parameters for reporting the BUS references and control words.

16-80 Fieldbus CTW 1		
Range:	Function:	
0 N/A*	[0 - 65535 N/A]	View the two-byte Control word (CTW) received from the Bus-Master. Interpretation of the Control word depends on the fieldbus option installed and the Control word profile selected in par. 8-10 <i>Control Profile</i> . For more information please refer to the relevant fieldbus manual.

16-84 Comm. Option STW		
Range:	Function:	
0 N/A*	[0 - 65535 N/A]	View the extended fieldbus comm. option status word. For more information please refer to the relevant fieldbus manual.

16-85 FC Port CTW 1		
Range:	Function:	
0 N/A*	[0 - 65535 N/A]	View the two-byte Control word (CTW) received from the Bus-Master. Interpretation of the control word depends on the fieldbus option installed and the Control word profile selected in par. 8-10 <i>Control Profile</i> .

16-66 Digital Output [bin]		
Range:	Function:	
0*	[0 - 15]	View the binary value of all digital outputs.

6.2.27 16-9* Diagnosis Read-Outs

16-71 Relay Output [bin]		
Range:	Function:	
0 N/A*	[0 - 511 N/A]	View the settings of all relays.

16-90 Alarm Word		
Range:	Function:	
0 N/A*	[0 - 4294967295 N/A]	View the alarm word sent via the serial communication port in hex code.

16-91 Alarm Word 2		
Range:	Function:	
0*	[0 - 4294967295]	View the alarm word sent via the serial communication port in hex code.

16-92 Warning Word		
Range:	Function:	
0 N/A*	[0 - 4294967295 N/A]	View the warning word sent via the serial communication port in hex code.

16-93 Warning Word 2		
Range:	Function:	
0*	[0 - 4294967295]	View the warning word sent via the serial communication port in hex code.

16-94 Ext. Status Word		
Range:	Function:	
0*	[0 - 4294967295]	Returns the extended warning word sent via the serial communication port in hex code.

300-00 Harmonic Cancellation Mode		
Option:	Function:	
[0] *	Overall	
[1]	Selective	
[2]	Parallel	Enter the harmonic compensation mode. Selective provides precise compensation of the following harmonics: 5,7,11,13,17,19,23,25. Overall provides compensation for additional harmonics, but with reduced precision in some cases.

300-10 Active Filter Nominal Voltage		
Range:	Function:	
Application dependent*	[Application dependant]	Enter the network voltage at the location where the active filter is installed. This value will be different than the 300-22 only if a step down transformer is used to connect the active filter. Enter the transformer secondary side voltage.

300-20 CT Primary Rating		
Range:	Function:	
Application dependent*	[1 - 4000 A]	Enter the primary rating of the current transformers. For a 1000:5 current transformer, enter 1000. Alternatively, this value can be determined by performing an auto CT detection using parameter 300-29.

300-21 CT Secondary Rating		
Option:	Function:	
[0]	1A	

300-21 CT Secondary Rating		
Option:	Function:	
[1] *	5A	Enter the secondary rating of the current transformers. For a 1000:5 current transformer, enter 5. This value can not be determined by performing an auto CT detection.

300-22 CT Nominal Voltage		
Range:	Function:	
342 V*	[342 - 47250 V]	Enter the network voltage at the location where the CTs are installed. This value will be different than the 300-10 only if a step down transformer is used to connect the active filter. Enter the transformer primary side voltage.

300-24 CT Sequence		
Option:	Function:	
[0] *	L1, L2, L3	
[1]	L1, L3, L2	
[2]	L2, L1, L3	
[3]	L2, L3, L1	
[4]	L3, L1, L2	
[5]	L3, L2, L1	Enter the sequence of the current transformers. Alternatively, this value can be determined by performing an auto CT detection using parameter 300-29.

300-25 CT Polarity		
Option:	Function:	
[0] *	Normal	
[1]	Inverse	Enter the polarity of the current transformers. Alternatively, this value can be determined by performing an auto CT detection using parameter 300-29.

300-26 CT Placement		
Option:	Function:	
[0]	PCC	
[1] *	Load Current	Enter the placement of the current transformers. For a stand alone active filter installation, the CTs will typically be placed at a PCC.

300-29 Start Auto CT Detection		
Option:	Function:	
[0] *	Off	
[1]	Enable Auto CT Detection	When enabled, the auto CT detection will determine the CT primary rating, CT sequence, and CT polarity. CT Secondary Rating, CT Nominal Voltage and CT Placement must be entered by the user before starting the auto CT detection. Automatic CT detection cannot be performed on CTs placed at the load currents.

300-30 Compensation Points		
Range:		Function:
0.0 A*	[0.0 - 8000.1 A]	Enter the max accepted distortion of the current in amps. Change these values to customize the harmonic compensation. It is possible to change the compensation points for the following harmonics: 5,7,11,13,17,19,23,25. Selective mode provides compensation of individual harmonics with permitted residual levels on the supply mains. The parameter "Compensation Point" defines the permitted residual level into the supply of the following harmonics.

300-35 Cosphi Reference		
Range:		Function:
0.500*	[0.500 - 1.000]	Enter the reference for cosphi.

300-40 Master Follower Selection		
Option:		Function:
[0]	Master	If operating active filters in parallel, select whether this AF is a master or a follower active filter.
[1]	Follower	
[2] *	Not Paralleled	

300-41 Follower ID		
Range:		Function:
1*	[1 - 3]	Enter the unique ID of this follower. Verify that no other follower uses the same ID.

300-42 Num. of Parallel AFs		
Range:		Function:
1*	[1 - 3]	Enter the total number of follower active filters. The master active filter will only control this number of followers.

301-00 Output Current [A]		
Range:		Function:
0.00 A*	[0.00 - 10000.00 A]	View the RMS output current of the unit.

301-01 Output Current [%]		
Range:		Function:
0.0 %*	[0.0 - 10000.0 %]	View the RMS output current of the unit, expressed as a percentage of the nominal current.

301-10 THD of Current [%]		
Range:		Function:
0 %*	[0 - 200 %]	View the resistor heatsink temperature.

301-11 Estimated THD of Voltage [%]		
Range:		Function:
0 %*	[0 - 200 %]	View the total harmonic distortion of the voltage. This value is estimated because the active filter does not measure the mains voltage.

301-12 Power Factor		
Range:		Function:
0.00*	[0.00 - 2.00]	View the power factor, after compensation by the active filter.

301-13 Cosphi		
Range:		Function:
0.00*	[-1.00 - 2.00]	View the displacement power factor, after compensation by the active filter. Positive numbers indicate a leading power factor, while negative numbers indicate a lagging power factor.

301-14 Leftover Currents		
Range:		Function:
0.0 A*	[0.0 - 8000.0 A]	View the harmonic currents leftover after prioritized harmonic and cos phi compensation by the active filter.

301-20 Mains Current [A]		
Range:		Function:
0 A*	[0 - 65000 A]	View the total harmonic distortion of the current, after compensation by the active filter.

301-21 Mains Frequency		
Range:		Function:
0 Hz*	[0 - 100 Hz]	View the total harmonic distortion of the voltage.

301-22 Fund. Mains Current [A]		
Range:		Function:
0 A*	[0 - 65000 A]	View the power factor, after compensation by the active filter.

6.2 Parameter Lists

6.3.1 Default settings

Changes during operation:

“TRUE” means that the parameter can be changed while the Active Filter is in operation and “FALSE” means that the unit must be stopped before a change can be made.

4-Set-up:

'All set-up': the parameter can be set individually in each of the four set-ups, i. e. one single parameter can have four different data values.

'1 set-up': data value will be the same in all set-ups.

SR:

Size related

N/A:

No default value available.

Conversion index:

This number refers to a conversion figure used when writing or reading by means of an active filter.

Conv. index	100	75	74	70	67	6	5	4	3	2	1	0	-1	-2	-3	-4	-5	-6
Conv. factor	1	3600000	3600	60	1/60	100000 0	10000 0	10000	1000	100	10	1	0.1	0.01	0.001	0.000 1	0.00001	0.00000 1

Data type	Description	Type
2	Integer 8	Int8
3	Integer 16	Int16
4	Integer 32	Int32
5	Unsigned 8	UInt8
6	Unsigned 16	UInt16
7	Unsigned 32	UInt32
9	Visible String	VisStr
33	Normalized value 2 bytes	N2
35	Bit sequence of 16 boolean variables	V2
54	Time difference w/o date	TimD

6.3.2 Operation/Display 0-**

Par. No. #	Parameter description	Default value	4-set-up	FC 302 only	Change during operation	Conversion index	Type
0-0* Basic Settings							
0-01	Language	[0] English	1 set-up		TRUE	-	Uint8
0-04	Operating State at Power-up (Hand)	[1] Forced stop	All set-ups		TRUE	-	Uint8
0-1* Set-up Operations							
0-10	Active Set-up	[1] Set-up 1	1 set-up		TRUE	-	Uint8
0-11	Edit Set-up	[1] Set-up 1	All set-ups		TRUE	-	Uint8
0-12	This Set-up Linked to	[0] Not linked	All set-ups		FALSE	-	Uint8
0-13	Readout: Linked Set-ups	0 N/A	All set-ups		FALSE	0	Uint16
0-14	Readout: Edit Set-ups / Channel	0 N/A	All set-ups		TRUE	0	Int32
0-2* LCP Display							
0-20	Display Line 1.1 Small	30112	All set-ups		TRUE	-	Uint16
0-21	Display Line 1.2 Small	30110	All set-ups		TRUE	-	Uint16
0-22	Display Line 1.3 Small	30120	All set-ups		TRUE	-	Uint16
0-23	Display Line 2 Large	30100	All set-ups		TRUE	-	Uint16
0-24	Display Line 3 Large	30121	All set-ups		TRUE	-	Uint16
0-25	My Personal Menu	ExpressionLimit	1 set-up		TRUE	0	Uint16
0-4* LCP Keypad							
0-40	[Hand on] Key on LCP	[1] Enabled	All set-ups		TRUE	-	Uint8
0-41	[Off] Key on LCP	[1] Enabled	All set-ups		TRUE	-	Uint8
0-42	[Auto on] Key on LCP	[1] Enabled	All set-ups		TRUE	-	Uint8
0-43	[Reset] Key on LCP	[1] Enabled	All set-ups		TRUE	-	Uint8
0-5* Copy/Save							
0-50	LCP Copy	[0] No copy	All set-ups		FALSE	-	Uint8
0-51	Set-up Copy	[0] No copy	All set-ups		FALSE	-	Uint8
0-6* Password							
0-60	Main Menu Password	100 N/A	1 set-up		TRUE	0	Int16
0-61	Access to Main Menu w/o Password	[0] Full access	1 set-up		TRUE	-	Uint8
0-65	Quick Menu Password	200 N/A	1 set-up		TRUE	0	Int16
0-66	Access to Quick Menu w/o Password	[0] Full access	1 set-up		TRUE	-	Uint8

6.3.3 Digital In/Out 5-**

Par. No. #	Parameter description	Default value	4-set-up	FC 302 only	Change during operation	Conversion index	Type
5-0* Digital I/O mode							
5-00	Digital I/O Mode	[0] PNP	All set-ups		FALSE	-	Uint8
5-01	Terminal 27 Mode	[0] Input	All set-ups		TRUE	-	Uint8
5-02	Terminal 29 Mode	[0] Input	All set-ups	x	TRUE	-	Uint8
5-1* Digital Inputs							
5-10	Terminal 18 Digital Input	[8] Start	All set-ups		TRUE	-	Uint8
5-11	Terminal 19 Digital Input	[0] No operation	All set-ups		TRUE	-	Uint8
5-12	Terminal 27 Digital Input	[0] No operation	All set-ups		TRUE	-	Uint8
5-13	Terminal 29 Digital Input	[0] No operation	All set-ups		TRUE	-	Uint8
5-14	Terminal 32 Digital Input	[90] AC Contactor	All set-ups		TRUE	-	Uint8
5-15	Terminal 33 Digital Input	[91] DC Contactor	All set-ups		TRUE	-	Uint8
5-16	Terminal X30/2 Digital Input	[0] No operation	All set-ups		TRUE	-	Uint8
5-17	Terminal X30/3 Digital Input	[0] No operation	All set-ups		TRUE	-	Uint8
5-18	Terminal X30/4 Digital Input	[0] No operation	All set-ups		TRUE	-	Uint8
5-19	Terminal 37 Safe Stop	[1] Safe Stop Alarm	1 set-up		TRUE	-	Uint8
5-3* Digital Outputs							
5-30	Terminal 27 Digital Output	[0] No operation	All set-ups		TRUE	-	Uint8
5-31	Terminal 29 Digital Output	[0] No operation	All set-ups	x	TRUE	-	Uint8
5-4* Relays							
5-40	Function Relay	[0] No operation	All set-ups		TRUE	-	Uint8
5-41	On Delay, Relay	0.30 s	All set-ups		TRUE	-2	Uint16
5-42	Off Delay, Relay	0.30 s	All set-ups		TRUE	-2	Uint16

6.3.4 Comm. and Options 8-**

Par. No. #	Parameter description	Default value	4-set-up	FC 302 only	Change during operation	Conversion index	Type
8-0* General Settings							
8-01	Control Site	[0] Digital and ctrl.word	All set-ups		TRUE	-	Uint8
8-02	Control Word Source	null	All set-ups		TRUE	-	Uint8
8-03	Control Word Timeout Time	1.0 s	1 set-up		TRUE	-1	Uint32
8-04	Control Word Timeout Function	[0] Off	1 set-up		TRUE	-	Uint8
8-05	End-of-Timeout Function	[1] Resume set-up	1 set-up		TRUE	-	Uint8
8-06	Reset Control Word Timeout	[0] Do not reset	All set-ups		TRUE	-	Uint8
8-3* FC Port Settings							
8-30	Protocol	[1] FC MC	1 set-up		TRUE	-	Uint8
8-31	Address	2 N/A	1 set-up		TRUE	0	Uint8
8-32	FC Port Baud Rate	[2] 9600 Baud	1 set-up		TRUE	-	Uint8
8-35	Minimum Response Delay	10 ms	All set-ups		TRUE	-3	Uint16
8-36	Max Response Delay	5000 ms	1 set-up		TRUE	-3	Uint16
8-37	Max Inter-Char Delay	25 ms	1 set-up		TRUE	-3	Uint16
8-5* Digital/Bus							
8-53	Start Select	[3] Logic OR	All set-ups		TRUE	-	Uint8
8-55	Set-up Select	[3] Logic OR	All set-ups		TRUE	-	Uint8

6.3.5 Special Functions 14-**

Par. No. #	Parameter description	Default value	4-set-up	FC 302 only	Change during operation	Conversion index	Type
14-2* Trip Reset							
14-20	Reset Mode	[0] Manual reset	All set-ups		TRUE	-	Uint8
14-21	Automatic Restart Time	10 s	All set-ups		TRUE	0	Uint16
14-22	Operation Mode	[0] Normal operation	All set-ups		TRUE	-	Uint8
14-23	Typecode Setting	null	2 set-ups		FALSE	-	Uint8
14-28	Production Settings	[0] No action	All set-ups		TRUE	-	Uint8
14-29	Service Code	0 N/A	All set-ups		TRUE	0	Int32
14-5* Environment							
14-50	RFI Filter	[1] On	1 set-up		FALSE	-	Uint8
14-53	Fan Monitor	[1] Warning	All set-ups		TRUE	-	Uint8
14-54	Bus Partner	1 N/A	2 set-ups		TRUE	0	Uint16

6.3.6 FC Information 15-**

Par. No. #	Parameter description	Default value	4-set-up	FC 302 only	Change during operation	Conversion index	Type
15-0* Operating Data							
15-00	Operating Hours	0 h	All set-ups		FALSE	74	Uint32
15-01	Running Hours	0 h	All set-ups		FALSE	74	Uint32
15-03	Power Up's	0 N/A	All set-ups		FALSE	0	Uint32
15-04	Over Temp's	0 N/A	All set-ups		FALSE	0	Uint16
15-05	Over Volt's	0 N/A	All set-ups		FALSE	0	Uint16
15-07	Reset Running Hours Counter	[0] Do not reset	All set-ups		TRUE	-	Uint8
15-1* Data Log Settings							
15-10	Logging Source	0	2 set-ups		TRUE	-	Uint16
15-11	Logging Interval	ExpressionLimit	2 set-ups		TRUE	-3	TimD
15-12	Trigger Event	[0] False	1 set-up		TRUE	-	Uint8
15-13	Logging Mode	[0] Log always	2 set-ups		TRUE	-	Uint8
15-14	Samples Before Trigger	50 N/A	2 set-ups		TRUE	0	Uint8
15-2* Historic Log							
15-20	Historic Log: Event	0 N/A	All set-ups		FALSE	0	Uint8
15-21	Historic Log: Value	0 N/A	All set-ups		FALSE	0	Uint32
15-22	Historic Log: Time	0 ms	All set-ups		FALSE	-3	Uint32
15-3* Fault Log							
15-30	Fault Log: Error Code	0 N/A	All set-ups		FALSE	0	Uint16
15-31	Fault Log: Value	0 N/A	All set-ups		FALSE	0	Int16
15-32	Fault Log: Time	0 s	All set-ups		FALSE	0	Uint32
15-4* Unit Identification							
15-40	FC Type	0 N/A	All set-ups		FALSE	0	VisStr[6]
15-41	Power Section	0 N/A	All set-ups		FALSE	0	VisStr[20]
15-42	Voltage	0 N/A	All set-ups		FALSE	0	VisStr[20]
15-43	Software Version	0 N/A	All set-ups		FALSE	0	VisStr[5]
15-44	Ordered Typecode String	0 N/A	All set-ups		FALSE	0	VisStr[40]
15-45	Actual Typecode String	0 N/A	All set-ups		FALSE	0	VisStr[40]
15-46	Unit Ordering No	0 N/A	All set-ups		FALSE	0	VisStr[8]
15-47	Power Card Ordering No	0 N/A	All set-ups		FALSE	0	VisStr[8]
15-48	LCP Id No	0 N/A	All set-ups		FALSE	0	VisStr[20]
15-49	SW ID Control Card	0 N/A	All set-ups		FALSE	0	VisStr[20]
15-50	SW ID Power Card	0 N/A	All set-ups		FALSE	0	VisStr[20]
15-51	Unit Serial Number	0 N/A	All set-ups		FALSE	0	VisStr[10]
15-53	Power Card Serial Number	0 N/A	All set-ups		FALSE	0	VisStr[19]
15-6* Option Ident							
15-60	Option Mounted	0 N/A	All set-ups		FALSE	0	VisStr[30]
15-61	Option SW Version	0 N/A	All set-ups		FALSE	0	VisStr[20]
15-62	Option Ordering No	0 N/A	All set-ups		FALSE	0	VisStr[8]
15-63	Option Serial No	0 N/A	All set-ups		FALSE	0	VisStr[18]
15-70	Option in Slot A	0 N/A	All set-ups		FALSE	0	VisStr[30]
15-71	Slot A Option SW Version	0 N/A	All set-ups		FALSE	0	VisStr[20]
15-72	Option in Slot B	0 N/A	All set-ups		FALSE	0	VisStr[30]
15-73	Slot B Option SW Version	0 N/A	All set-ups		FALSE	0	VisStr[20]
15-74	Option in Slot C0	0 N/A	All set-ups		FALSE	0	VisStr[30]
15-75	Slot C0 Option SW Version	0 N/A	All set-ups		FALSE	0	VisStr[20]
15-76	Option in Slot C1	0 N/A	All set-ups		FALSE	0	VisStr[30]
15-77	Slot C1 Option SW Version	0 N/A	All set-ups		FALSE	0	VisStr[20]

Par. No. #	Parameter description	Default value	4-set-up	FC 302 only	Change during operation	Conversion index	Type
15-9* Parameter Info							
15-92	Defined Parameters	0 N/A	All set-ups		FALSE	0	Uint16
15-93	Modified Parameters	0 N/A	All set-ups		FALSE	0	Uint16
15-98	Unit Identification	0 N/A	All set-ups		FALSE	0	VisStr[40]
15-99	Parameter Metadata	0 N/A	All set-ups		FALSE	0	Uint16

6.3.7 Data Readouts 16-**

Par. No. #	Parameter description	Default value	4-set-up	FC 302 only	Change during operation	Conversion index	Type
16-0* General Status							
16-00	Control Word	0 N/A	All set-ups		FALSE	0	V2
16-03	Status Word	0 N/A	All set-ups		FALSE	0	V2
16-3* AF Status							
16-30	DC Link Voltage	0 V	All set-ups		FALSE	0	Uint16
16-34	Heatsink Temp.	0 °C	All set-ups		FALSE	100	Uint8
16-35	Inverter Thermal	0 %	All set-ups		FALSE	0	Uint8
16-36	Inv. Nom. Current	ExpressionLimit	All set-ups		FALSE	-2	Uint32
16-37	Inv. Max. Current	ExpressionLimit	All set-ups		FALSE	-2	Uint32
16-39	Control Card Temp.	0 °C	All set-ups		FALSE	100	Uint8
16-40	Logging Buffer Full	[0] No	All set-ups		TRUE	-	Uint8
16-49	Current Fault Source	0 N/A	All set-ups		TRUE	0	Uint8
16-6* Inputs & Outputs							
16-60	Digital Input	0 N/A	All set-ups		FALSE	0	Uint16
16-66	Digital Output [bin]	0 N/A	All set-ups		FALSE	0	Int16
16-71	Relay Output [bin]	0 N/A	All set-ups		FALSE	0	Int16
16-8* Fieldbus & FC Port							
16-80	Fieldbus CTW 1	0 N/A	All set-ups		FALSE	0	V2
16-84	Comm. Option STW	0 N/A	All set-ups		FALSE	0	V2
16-85	FC Port CTW 1	0 N/A	All set-ups		FALSE	0	V2
16-9* Diagnosis Readouts							
16-90	Alarm Word	0 N/A	All set-ups		FALSE	0	Uint32
16-91	Alarm Word 2	0 N/A	All set-ups		FALSE	0	Uint32
16-92	Warning Word	0 N/A	All set-ups		FALSE	0	Uint32
16-93	Warning Word 2	0 N/A	All set-ups		FALSE	0	Uint32
16-94	Ext. Status Word	0 N/A	All set-ups		FALSE	0	Uint32

6.3.8 AF Settings 300-**

NOTE

Except for par. 300-10, it is not recommended to change the settings in this par. group for the Low Harmonic Drive

6

Par. No. #	Parameter description	Default value	4-set-up	FC 302 only	Change during operation	Conversion index	Type
300-0* General Settings							
300-00	Harmonic Cancellation Mode	[0] Overall	All set-ups		TRUE	-	Uint8
300-01	Compensation Priority	[0] Harmonics	All set-ups		TRUE	-	Uint8
300-1* Network Settings							
300-10	Active Filter Nominal Voltage	ExpressionLimit	2 set-ups		FALSE	0	Uint32
300-2* CT Settings							
300-20	CT Primary Rating	ExpressionLimit	2 set-ups		FALSE	0	Uint32
300-21	CT Secondary Rating	[1] 5A	2 set-ups		FALSE	-	Uint8
300-22	CT Nominal Voltage	342 V	2 set-ups		FALSE	0	Uint32
300-24	CT Sequence	[0] L1, L2, L3	2 set-ups		FALSE	-	Uint8
300-25	CT Polarity	[0] Normal	2 set-ups		FALSE	-	Uint8
300-26	CT Placement	[1] Load Current	2 set-ups		FALSE	-	Uint8
300-29	Start Auto CT Detection	[0] Off	All set-ups		FALSE	-	Uint8
300-3* Compensation							
300-30	Compensation Points	0.0 A	All set-ups		TRUE	-1	Uint32
300-35	Cosphi Reference	0.500 N/A	All set-ups		TRUE	-3	Uint16
300-40	Master Follower Selection	[2] Not Paralleled	2 set-ups				Uint8
300-41	Follower ID	1 N/A	2 set-ups				Uint32
300-42	Num. of Parallel AFs	1 N/A	2 set-ups				Uint32

6.3.9 AF Readouts 301-**

Par. No. #	Parameter description	Default value	4-set-up	FC 302 only	Change during operation	Conversion index	Type
301-0* Output Currents							
301-00	Output Current [A]	0.00 A	All set-ups		TRUE	-2	Int32
301-01	Output Current [%]	0.0 %	All set-ups		TRUE	-1	Int32
301-1* Unit Performance							
301-10	THD of Current [%]	0.0 %	All set-ups		TRUE	-1	Uint16
301-11	Estimated THD of Voltage [%]	0.0 %	All set-ups				Uint16
301-12	Power Factor	0.00 N/A	All set-ups		TRUE	-2	Uint16
301-13	Cosphi	0.00 N/A	All set-ups		TRUE	-2	Int16
301-14	Leftover Currents	0.0 A	All set-ups		TRUE	-1	Uint32
301-2* Mains Status							
301-20	Mains Current [A]	0 A	All set-ups		TRUE	0	Int32
301-21	Mains Frequency	0 Hz	All set-ups		TRUE	0	Uint8
301-22	Fund. Mains Current [A]	0 A	All set-ups		TRUE	0	Int32

7 RS-485 Installation and Setup

7.1.1 Overview

RS-485 is a two-wire bus interface compatible with multi-drop network topology, i.e. nodes can be connected as a bus, or via drop cables from a common trunk line. A total of 32 nodes can be connected to one network segment.

Network segments are divided up by repeaters. Please note that each repeater functions as a node within the segment in which it is installed. Each node connected within a given network must have a unique node address, across all segments.

Terminate each segment at both ends, using either the termination switch (S801) of the unit or a biased termination resistor network. Always use screened twisted pair (STP) cable for bus cabling, and always follow good common installation practice.

Low-impedance ground connection of the screen at every node is very important, including at high frequencies. This can be achieved by connecting a large surface of the screen to ground, for example by means of a cable clamp or a conductive cable gland. It may be necessary to apply potential-equalizing cables to maintain the same ground potential throughout the network, particularly in installations where there are long lengths of cable.

To prevent impedance mismatch, always use the same type of cable throughout the entire network.

Cable: Screened twisted pair (STP)
Impedance: 120 Ohm
Cable length: Max. 1200 m (including drop lines)
Max. 500 m station-to-station

7.1.2 Network Connection

Connect the unit to the RS-485 network as follows (see also diagram):

1. Connect signal wires to terminal 68 (P+) and terminal 69 (N-) on the main control board of the unit.
2. Connect the cable screen to the cable clamps.

NOTE

Screened, twisted-pair cables are recommended in order to reduce noise between conductors.

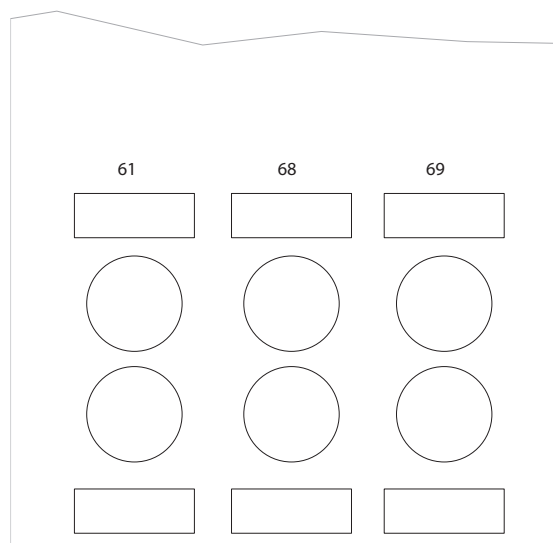

130BB022.10

Illustration 7.1: Network Terminal Connection

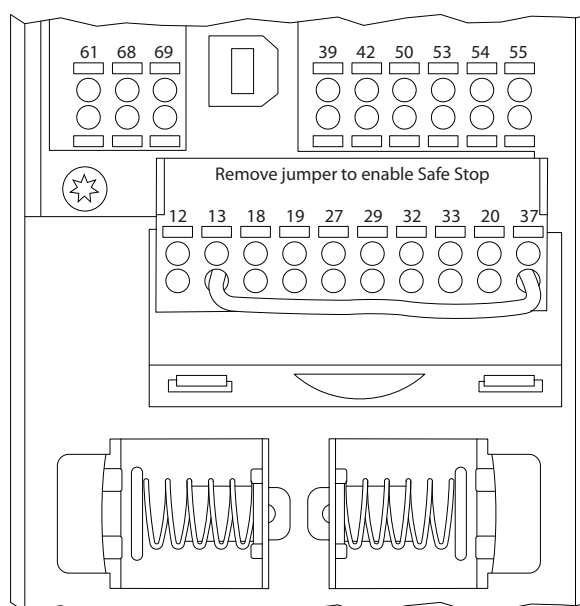

130BB021.10

Illustration 7.2: Control card terminals

7.1.3 RS-485 Bus Termination

Use the terminator dip switch on the main control board of the unit to terminate the RS-485 bus.

NOTE

The factory setting for the dip switch is OFF.

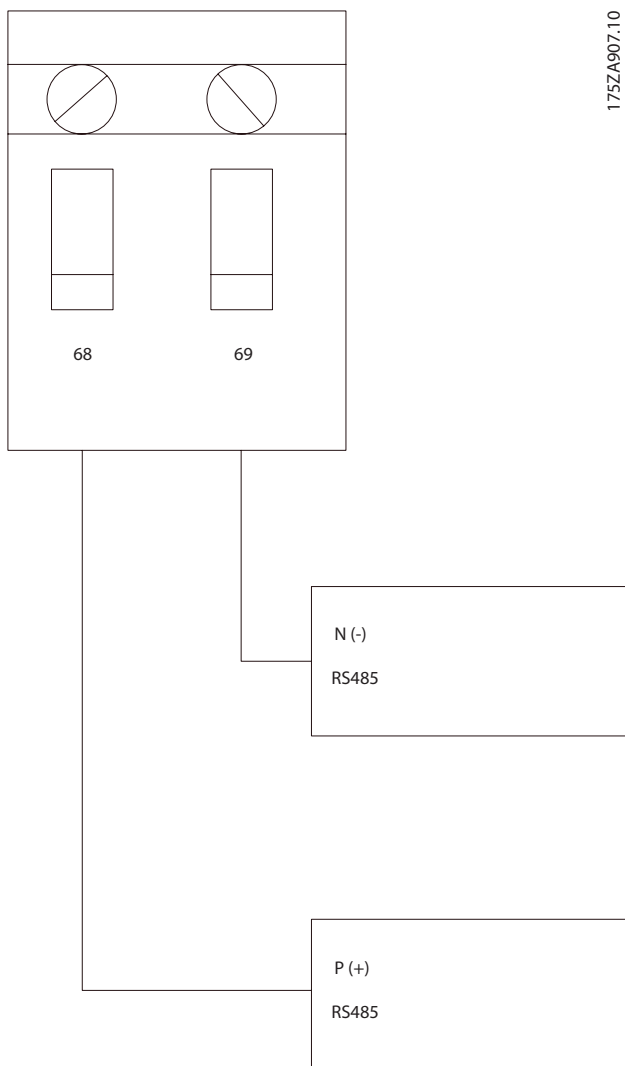

175ZA907.10

Terminator Switch Factory Setting

7.1.4 EMC Precautions

The following EMC precautions are recommended in order to achieve interference-free operation of the RS-485 network.

Relevant national and local regulations, for example regarding protective earth connection, must be observed. The RS-485 communication cable must be kept away from noisy cables such as power lines and motor cables to avoid coupling of high frequency noise from one cable to another. Normally a distance of 200 mm (8 inches) is sufficient, but keeping the greatest possible distance between the cables is generally recommended, especially where cables run in parallel over long distances. When crossing is unavoidable, the RS-485 cable must cross other power cables at an angle of 90 degrees.

The FC protocol, also referred to as FC bus or Standard bus, is the Danfoss standard fieldbus. It defines an access technique according to the master-slave principle for communications via a serial bus.

One master and a maximum of 126 slaves can be connected to the bus. The individual slaves are selected by the master via an address character in the telegram. A slave itself can never transmit without first being requested to do so, and direct message transfer between the individual slaves is not possible. Communications occur in the half-duplex mode.

The master function cannot be transferred to another node (single-master system).

The physical layer is RS-485, thus utilizing the RS-485 port built into the unit. The FC protocol supports different telegram formats; a short format of 8 bytes for process data, and a long format of 16 bytes that also includes a parameter channel. A third telegram format is used for texts.

7.1 Network Configuration

7.3.1 FC 300 Filter Set-up

Set the following parameters to enable the FC protocol for the filter.

Parameter Number	Setting
Par. 8-30 Protocol	FC
Par. 8-31 Address	1 - 126
Par. 8-32 FC Port Baud Rate	2400 - 115200
Par. 8-33 Parity / Stop Bits	Even parity, 1 stop bit (default)

7.2 FC Protocol Message Framing Structure

7.4.1 Content of a Character (byte)

Each character transferred begins with a start bit. Then 8 data bits are transferred, corresponding to a byte. Each character is secured via a parity bit, which is set at "1" when it reaches parity (i.e. when there is an equal number of 1's in the 8 data bits and the parity bit in total). A character is completed by a stop bit, thus consisting of 11 bits in all.



7.4.2 Telegram Structure

Each telegram begins with a start character (STX)=02 Hex, followed by a byte denoting the telegram length (LGE) and a byte denoting the filter address (ADR). A number of data bytes (variable, depending on the type of telegram) follows. The telegram is completed by a data control byte (BCC).

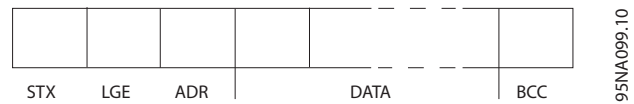

7.4.3 Telegram Length (LGE)

The telegram length is the number of data bytes plus the address byte ADR and the data control byte BCC.

The length of telegrams with 4 data bytes is	$LGE = 4 + 1 + 1 = 6$ bytes
The length of telegrams with 12 data bytes is	$LGE = 12 + 1 + 1 = 14$ bytes
The length of telegrams containing texts is	$10^{1)} + n$ bytes

¹⁾ The 10 represents the fixed characters, while the "n" is variable (depending on the length of the text).

7.4.4 Filter Address (ADR)

Two different address formats are used. The address range of the filter is either 1-31 or 1-126.

- Address format 1-31:
 Bit 7 = 0 (address format 1-31 active)
 Bit 6 is not used
 Bit 5 = 1: Broadcast, address bits (0-4) are not used
 Bit 5 = 0: No Broadcast
 Bit 0-4 = Filter address 1-31

- Address format 1-126:
 Bit 7 = 1 (address format 1-126 active)
 Bit 0-6 = Filter address 1-126
 Bit 0-6 = 0 Broadcast

The slave returns the address byte unchanged to the master in the response telegram.

7.4.5 Data Control Byte (BCC)

The checksum is calculated as an XOR-function. Before the first byte in the telegram is received, the Calculated Checksum is 0.

7.4.6 The Data Field

The structure of data blocks depends on the type of telegram. There are three telegram types, and the type applies for both control telegrams (master=>slave) and response telegrams (slave=>master).

The three types of telegram are:

- Process block (PCD):
 The PCD is made up of a data block of four bytes (2 words) and contains:
- Control word and reference value (from master to slave)
 - Status word and present output frequency (from slave to master).



130BA269.10

Parameter block:

The parameter block is used to transfer parameters between master and slave. The data block is made up of 12 bytes (6 words) and also contains the process block.

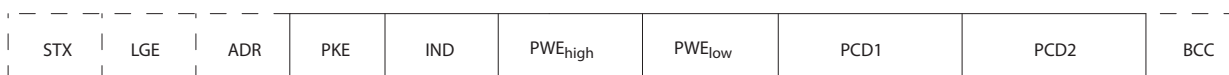

130BA271.10

Text block:

The text block is used to read or write texts via the data block.

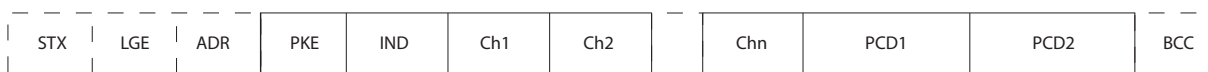

130BA270.10

7

7.4.7 The PKE Field

The PKE field contains two sub-fields: Parameter command and response AK, and Parameter number PNU:

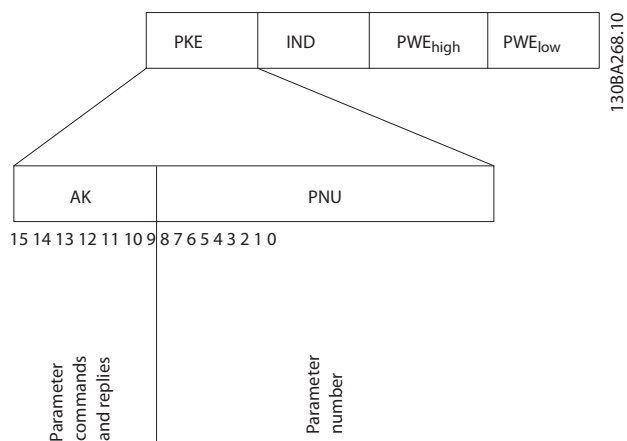

130BA268.10

Bits no. 12-15 transfer parameter commands from master to slave and return processed slave responses to the master.

Parameter commands master → slave				
Bit no.				Parameter command
15	14	13	12	
0	0	0	0	No command
0	0	0	1	Read parameter value
0	0	1	0	Write parameter value in RAM (word)
0	0	1	1	Write parameter value in RAM (double word)
1	1	0	1	Write parameter value in RAM and EEPROM (double word)
1	1	1	0	Write parameter value in RAM and EEPROM (word)
1	1	1	1	Read/write text

Response slave → master				
Bit no.				Response
15	14	13	12	
0	0	0	0	No response
0	0	0	1	Parameter value transferred (word)
0	0	1	0	Parameter value transferred (double word)
0	1	1	1	Command cannot be performed
1	1	1	1	text transferred

If the command cannot be performed, the slave sends this response:

0111 Command cannot be performed

- and issues the following fault report in the parameter value (PWE):

PWE low (Hex)	Fault Report
0	The parameter number used does not exist
1	There is no write access to the defined parameter
2	Data value exceeds the parameter's limits
3	The sub index used does not exist
4	The parameter is not the array type
5	The data type does not match the defined parameter
11	Data change in the defined parameter is not possible in the unit's present mode. Certain parameters can only be changed when the motor is turned off
82	There is no bus access to the defined parameter
83	Data change is not possible because factory setup is selected

7.4.8 Parameter Number (PNU)

Bits no. 0-11 transfer parameter numbers. The function of the relevant parameter is defined in the parameter description in the Programming Guide.

7.4.9 Index (IND)

The index is used together with the parameter number to read/write-access parameters with an index, e.g. par. 15-30 *Alarm Log: Error Code*. The index consists of 2 bytes, a low byte and a high byte.

Only the low byte is used as an index.

7.4.10 Parameter Value (PWE)

The parameter value block consists of 2 words (4 bytes), and the value depends on the defined command (AK). The master prompts for a parameter value when the PWE block contains no value. To change a parameter value (write), write the new value in the PWE block and send from the master to the slave.

When a slave responds to a parameter request (read command), the present parameter value in the PWE block is transferred and returned to the master. If a parameter contains not a numerical value but several data options, e.g. par. 0-01 *Language* where [0] corresponds to English, and [4] corresponds to Danish, select the data value by entering the value in the PWE block. See Example - Selecting a data value. Serial communication is only capable of reading parameters containing data type 9 (text string).

Par. 15-40 *FC Type* to par. 15-53 *Power Card Serial Number* contain data type 9.

For example, read the unit size and mains voltage range in par. 15-40 *FC Type*. When a text string is transferred (read), the length of the telegram is variable, and the texts are of different lengths. The telegram length is defined in the second byte of the telegram, LGE. When using text transfer the index character indicates whether it is a read or a write command.

To read a text via the PWE block, set the parameter command (AK) to 'F' Hex. The index character high-byte must be "4".

Some parameters contain text that can be written to via the serial bus. To write a text via the PWE block, set the parameter command (AK) to 'F' Hex. The index characters high-byte must be "5".

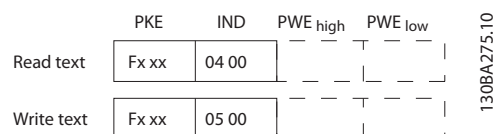

7.4.11 Data Types Supported by FC 300

Unsigned means that there is no operational sign in the telegram.

Data types	Description
3	Integer 16
4	Integer 32
5	Unsigned 8
6	Unsigned 16
7	Unsigned 32
9	Text string
10	Byte string
13	Time difference
33	Reserved
35	Bit sequence

7.4.12 Conversion

The various attributes of each parameter are displayed in the section Factory Settings. Parameter values are transferred as whole numbers only. Conversion factors are therefore used to transfer decimals.

Par. 4-12 *Motor Speed Low Limit [Hz]* has a conversion factor of 0.1.

To preset the minimum frequency to 10 Hz, transfer the value 100. A conversion factor of 0.1 means that the value transferred is multiplied by 0.1. The value 100 is thus perceived as 10.0.

Conversion table	
Conversion index	Conversion factor
74	0.1
2	100
1	10
0	1
-1	0.1
-2	0.01
-3	0.001
-4	0.0001
-5	0.00001

7.4.13 Process Words (PCD)

The block of process words is divided into two blocks of 16 bits, which always occur in the defined sequence.

PCD 1	PCD 2
Control telegram (master⇒slave) Control word	Reference-value
Control telegram (slave ⇒master) Status word	Present outp. frequency

7.3 How to Access Parameters

7.5.1 Parameter Handling

The PNU (Parameter Number) is translated from the register address contained in the Modbus read or write message. The parameter number is translated to Modbus as (10 x parameter number) DECIMAL.

7.5.2 Storage of Data

The Coil 65 decimal determines whether data written to the unit are stored in EEPROM and RAM (coil 65 = 1) or only in RAM (coil 65 = 0).

7.5.3 IND

The array index is set in Holding Register 9 and used when accessing array parameters.

7.5.4 Text Blocks

Parameters stored as text strings are accessed in the same way as the other parameters. The maximum text block size is 20 characters. If a read request for a parameter is for more characters than the parameter stores, the response is truncated. If the read request for a parameter is for fewer characters than the parameter stores, the response is space filled.

7.5.5 Conversion Factor

The different attributes for each parameter can be seen in the section on factory settings. Since a parameter value can only be transferred as a whole number, a conversion factor must be used to transfer decimals. Please refer to the *Parameters section*.

7.5.6 Parameter Values

Standard Data Types

Standard data types are int16, int32, uint8, uint16 and uint32. They are stored as 4x registers (40001 – 4FFFF). The parameters are read using function 03HEX "Read Holding Registers." Parameters are written using the function 6HEX "Preset Single Register" for 1 register (16 bits), and the function 10HEX "Preset Multiple Registers" for 2 registers (32 bits). Readable sizes range from 1 register (16 bits) up to 10 registers (20 characters).

Non standard Data Types

Non standard data types are text strings and are stored as 4x registers (40001 – 4FFFF). The parameters are read using function 03HEX "Read Holding Registers" and written using function 10HEX "Preset Multiple Registers." Readable sizes range from 1 register (2 characters) up to 10 registers (20 characters).

8 General Specifications

8.1 Electrical Data

8.1.1 Power Rating

Grid conditions:

Supply voltage 380-480 V

Mains voltage low / mains drop-out:

During low mains voltage or a mains drop-out, the Filter continues until the intermediate circuit voltage drops below the minimum stop level, which corresponds typically to 15% below the filter lowest rated supply voltage. Full compensation cannot be expected at mains voltage lower than 10% below the filter lowest rated supply voltage. If mains voltage exceed the filter highest rated voltage the filter continues to work but harmonic mitigation performance is reduced. Filter will not cut out until main voltages exceed 580V.

Supply frequency 50/60 Hz \pm 5%

Max. imbalance temporary between mains phases 3.0 % of rated supply voltage

where mitigation performance is kept high. Filter will mitigate at higher mains imbalance but harmonic mitigation performance is reduced

10% with kept mitigation performance

Max THDv pre-distortion Reduced performance for higher pre-distortion levels

Harmonic Mitigation Performance:

THiD Best performance <4%

Depending on filter vs. distortion ratio.

Individual harmonic mitigation ability: % of filter current rating

5th 70%

7th 50%

11th 32%

13th 28%

17th 20%

19th 18%

23rd 16%

25th 14%

Total current of harmonics 90%

Reactive Current Compensation:

Cos phi Controllable 1.0 to 0.5 lagging

Reactive current, % of filter current rating 100%

Cable lengths and cross sections:

Max grid cable length Unlimited (determined by voltage drop)

Maximum cross section to control terminals, rigid wire 1.5 mm²/16 AWG (2 x 0.75 mm²)

Maximum cross section to control terminals, flexible cable 1 mm²/18 AWG

Maximum cross section to control terminals, cable with enclosed core 0.5 mm²/20 AWG

Minimum cross section to control terminals 0.25 mm²

CT terminals specification:

Needed CT number 3 (one for each phase)

AAF's burden equals 2m Ω

Secondary current rating 1A or 5A

Accuracy Class 1 or better

Digital inputs:

Programmable digital inputs 2 (4)

Terminal number 18, 19, 27*, 29*

Logic PNP or NPN

Voltage level 0 - 24 V DC

Voltage level, logic '0' PNP	< 5 V DC
Voltage level, logic '1' PNP	> 10 V DC
Voltage level, logic '0' NPN	> 19 V DC
Voltage level, logic '1' NPN	< 14 V DC
Maximum voltage on input	28 V DC
Input resistance, R _i	approx. 4 kΩ

All digital inputs are galvanically isolated from the supply voltage (PELV) and other high-voltage terminals.

*) Terminals 27 and 29 can also be programmed as output.

Control card, RS-485 serial communication:

Terminal number	68 (P,TX+, RX+), 69 (N,TX-, RX-)
Terminal number 61	Common for terminals 68 and 69

The RS-485 serial communication circuit is functionally seated from other central circuits and galvanically isolated from the supply voltage (PELV).

Digital output:

Programmable digital/pulse outputs	2
Terminal number	27, 29 ¹⁾
Voltage level at digital/frequency output	0 - 24 V
Max. output current (sink or source)	40 mA
Max. load at frequency output	1 kΩ
Max. capacitive load at frequency output	10 nF
Minimum output frequency at frequency output	0 Hz
Maximum output frequency at frequency output	32 kHz
Accuracy of frequency output	Max. error: 0.1 % of full scale
Resolution of frequency outputs	12 bit

1) Terminal 27 and 29 can also be programmed as input.

Control card, 24 V DC output:

Terminal number	13
Max. load	: 200 mA

The 24 V DC supply is galvanically isolated from the supply voltage (PELV), but has the same potential as the analog and digital inputs and outputs.

Surroundings:

Enclosure	IP 21, IP 54 (hybrid)
Vibration test	0.7 g
Relative humidity	5% - 95%(IEC 721-3-3; Class 3K3 (non-condensing) during operation
Aggressive environment (IEC 60068-2-43) H ₂ S test	class kD
Test method according to IEC 60068-2-43 H ₂ S (10 days)	
Ambient temperature	
- with derating	max. NA ° C
- with full output current (short temperature overload)	max. 45 ° C
- at full continuous output current (24 hours)	max. 40 ° C
Minimum ambient temperature during full-scale operation	0 ° C
Minimum ambient temperature at reduced performance	- 10 ° C
Temperature during storage/transport	-25 to +70 ° C
Maximum altitude above sea level without derating	1000 m
Maximum altitude above sea level with derating	3000 m
EMC standards, Emission	EN 61800-3, EN 61000-6-3/4, EN 55011, IEC 61800-3 EN 61800-3, EN 61000-6-1/2,
EMC standards, Immunity	EN 61000-4-2, EN 61000-4-3, EN 61000-4-4, EN 61000-4-5, EN 61000-4-6

Control card performance:

Scan interval	: 5 ms
---------------	--------

Control card, USB serial communication:

USB standard	1.1 (Full speed)
USB plug	USB type B "device" plug

Generic specifications:

Maximum parallel filters	4 on same CT set
Filter Efficiency	97%
Typical average switching frequency	3.0 – 4.5 kHz
Response time	< 0,5 ms
Settling time - reactive current control	< 20 ms
Settling time - harmonic current control	< 15 ms
Overshoot – reactive current control	<10%
Overshoot – Harmonic current control	<10%

Connection to PC is carried out via a standard host/device USB cable. The USB connection is galvanically isolated from the supply voltage (PELV) and other high-voltage terminals. The USB connection is not galvanically isolated from protection earth. Use only isolated laptop/PC as connection to the USB connector on the unit or an isolated USB cable/converter.

Protection and Features:

- Temperature monitoring of the heatsink ensures that the active filter trips if the temperature reaches a predefined level. An overload temperature cannot be reset until the temperature of the heatsink is below the values stated in the tables on the following pages.
- If a mains phase is missing, the Active filter trips.
- Monitoring of the intermediate circuit voltage ensures that the filter trips if the intermediate circuit voltage is too low or too high.
- The Active filter monitors the mains current as well as internal currents to reassure that current levels do not reach critical levels. In case current exceed a critical level the filter trips.

				AAF 005A190T4 E21H2GCx x	AAF 005A210T 4E21H2GC xx LHD filter only	AAF 005A250T4 E21H2GCx x	AAF 005A310T4 E21H2GCx x	AAF 005A330T4 E21H2GCx x LHD filter only	AAF 005A400T4 E21H2GCx x	AAF 005A500T4 E21H2GCx x
Total	Current	[A]		190		250	310		400	500
Losses	Watt	[kW]								
Needed Airflow		M ³ /h								
Frame				D		E		F		
Nominal	Reactive	[A]		190		250	310		400	500
Nominal	Harmonic	[A]		170		225	280		360	450
Max individual harmonic compensa- tion	I ₅			119		158	196		252	315
				-131		-173	-216		-277	-347
Nominal/ (maximum)	I ₇			85		113	140		180	225
				-94		-124	-154		-198	-248
Note: Numbers are rounded to nearest amp	I ₁₁			54		72	90		115	144
				-60		-79	-99		-127	-158
	I ₁₃			48		63	78		101	126
				-52		-69	-86		-111	-139
	I ₁₇			34		45	56		72	90
				-37		-50	-62		-79	-99
	I ₁₉			31		41	50		65	81
				-34		-45	-55		-71	-89
	I ₂₃			27		36	45		58	72
				-30		-40	-49		-63	-79
	I ₂₅			24		32	39		50	63
				-26		-35	-43		-55	-69

9 Troubleshooting

A warning or an alarm is signalled by the relevant LED on the front of the filter and indicated by a code on the display.

A warning remains active until its cause is no longer present. Under certain circumstances operation may still be continued. Warning messages are not critical for the filter operation and is often an indication that the filter has reached its maximum current capability. Even if filter compensation current is low some higher order corrected harmonics might have reached the filter maximum capability resulting in an overload warning. Only critical warnings will, if not automatically resolved, generate an alarm.

In the event of an alarm, the Active Filter will have tripped. Alarms must be reset to restart operation once their cause has been rectified.

This may be done in four ways:

1. By using the [RESET] control button on the LCP control panel.
2. Via a digital input with the "Reset" function.
3. Via serial communication/optional fieldbus.
4. By resetting automatically using the [Auto Reset] function. See par. 14-20 *Reset Mode* in the **How to Programme** chapter.

NOTE

After a manual reset using the [RESET] button on the LCP, the [AUTO ON] or [HAND ON] button must be pressed to restart the unit.

If an alarm cannot be reset, the reason may be that its cause has not been rectified, or the alarm is trip-locked (see also table on following page).

Alarms that are trip-locked offer additional protection, means that the mains supply must be switched off before the alarm can be reset. After being switched back on, the device is no longer blocked and may be reset as described above once the cause has been rectified.

Alarms that are not trip-locked can also be reset using the automatic reset function in par. 14-20 *Reset Mode* (Warning: automatic wake-up is possible!)

If a warning and alarm is marked against a code in the table on the following page, this means that either a warning occurs before an alarm, or it can be specified whether it is a warning or an alarm that is to be displayed for a given fault.

No.	Description	Warning	Alarm/Trip	Alarm/Trip Lock	Parameter Reference
1	10 Volts low	X			
2	Live zero error	(X)	(X)		6-01
4	Mains phase loss		X		
5	DC link voltage high	X			
6	DC link voltage low	X			
7	DC over voltage	X	X		
8	DC under voltage	X	X		
13	Over Current	X	X	X	
14	Earth fault	X	X	X	
15	Hardware mismatch		X	X	
16	Short Circuit		X	X	
17	Control word timeout	(X)	(X)		8-04
23	Internal Fan Fault	X			
24	External Fan Fault	X			14-53
29	Heatsink temp	X	X	X	
33	Inrush fault		X	X	
34	Fieldbus fault	X	X		
35	Option fault	X	X		
38	Internal fault				
39	Heatsink sensor		X	X	
40	Overload of Digital Output Terminal 27	(X)			5-00, 5-01
41	Overload of Digital Output Terminal 29	(X)			5-00, 5-02
42	Overload of Digital Output On X30/6	(X)			5-32
42	Overload of Digital Output On X30/7	(X)			5-33

No.	Description	Warning	Alarm/Trip	Alarm/Trip Lock	Parameter Reference
46	Pwr. card supply		X	X	
47	24 V supply low	X	X	X	
48	1.8 V supply low		X	X	
65	Control Board Over-temperature	X	X	X	
66	Heat sink Temperature Low	X			
67	Option Configuration has Changed		X		
68	Safe Stop Activated		X ¹⁾		
69	Pwr. Card Temp		X	X	
70	Illegal FC configuration			X	
72	Dangerous Failure			X ¹⁾	
73	Safe Stop Auto Restart				
76	Power Unit Setup	X			
79	Illegal PS config		X	X	
80	Drive Initialised to Default Value		X		
244	Heatsink temp	X	X	X	
245	Heatsink sensor		X	X	
246	Pwr.card supply		X	X	
247	Pwr.card temp		X	X	
248	Illegal PS config		X	X	
250	New spare part			X	
251	New Type Code		X	X	
300	Mains Cont. fault			X	
301	SC Cont. Fault			X	
302	Cap. Over Current	X	X		
303	Cap. Earth Fault	X	X		
304	DC Over Current	X	X		
305	Mains Freq. Limit		X		
308	Resistor temp	X		X	
309	Mains Earth Fault	X	X		
311	Switch. Freq. Limit		X		
314	Auto CT Interrupt		X		
315	Auto CT Error		X		
316	CT Location Error		X		
317	CT Polarity Error		X		
318	CT Ratio Error		X		

Table 9.1: Alarm/Warning code list

A trip is the action when an alarm has appeared. The trip will stop the filter operation and can be reset by pressing the reset button or make a reset by a digital input (Par. 5-1* [1]). The origin event that caused an alarm cannot damage the filter or cause dangerous conditions. A trip lock is an action when an alarm occurs, which may cause damage to the device or connected parts. A Trip Lock situation can only be reset by a power cycling.

LED indication	
Warning	yellow
Alarm	flashing red
Trip locked	yellow and red

Alarm Word and Extended Status Word					
Bit	Hex	Dec	Alarm Word	Warning Word	Extended Status Word
0	00000001	1	Mains Cont. Fault	Reserved	Reserved
1	00000002	2	Heatsink Temp	Heatsink Temp	Auto CT Running
2	00000004	4	Earth Fault	Earth Fault	Reserved
3	00000008	8	Ctrl.Card Temp	Ctrl.Card Temp	Reserved
4	00000010	16	Ctrl. Word TO	Ctrl. Word TO	Reserved
5	00000020	32	Over Current	Over Current	Reserved
6	00000040	64	SC Cont. Fault	Reserved	Reserved
7	00000080	128	Cap. Over Current	Cap. Over Current	Reserved
8	00000100	256	Cap. Earth Fault	Cap. Earth Fault	Reserved
9	00000200	512	Inverter Overld.	Inverter Overld.	Reserved
10	00000400	1024	DC under Volt	DC under Volt	Reserved
11	00000800	2048	DC over Volt	DC over Volt	Reserved
12	00001000	4096	Short Circuit	DC Voltage Low	Reserved
13	00002000	8192	Inrush Fault	DC Voltage High	Reserved
14	00004000	16384	Mains ph. Loss	Mains ph. Loss	Reserved
15	00008000	32768	Auto CT Error	Reserved	Reserved
16	00010000	65536	Reserved	Reserved	Reserved
17	00020000	131072	Internal Fault	10V Low	Password Time Lock
18	00040000	262144	DC Over Current	DC Over Current	Password Protection
19	00080000	524288	Resistor temp	Resistor temp	Reserved
20	00100000	1048576	Mains Earth Fault	Mains Earth Fault	Reserved
21	00200000	2097152	Switch. Freq. Limit	Reserved	Reserved
22	00400000	4194304	Fieldbus Fault	Fieldbus Fault	Reserved
23	00800000	8388608	24 V Supply Low	24V Supply Low	Reserved
24	01000000	16777216	CT Range	Reserved	Reserved
25	02000000	33554432	1.8V Supply Low	Reserved	Reserved
26	04000000	67108864	Reserved	Low Temp	Reserved
27	08000000	134217728	Auto CT Interrupt	Reserved	Reserved
28	10000000	268435456	Option Change	Reserved	Reserved
29	20000000	536870912	Unit Initialized	Unit Initialized	Reserved
30	40000000	1073741824	Safe Stop	Safe Stop	Reserved
31	80000000	2147483648	Mains Freq. Limit	Extended Status Word	Reserved

Table 9.2: Description of Alarm Word, Warning Word and Extended Status Word

The alarm words, warning words and extended status words can be read out via serial bus or optional fieldbus for diagnosis. See also par. 16-90 *Alarm Word*, par. 16-92 *Warning Word* and par. 16-94 *Ext. Status Word*. "Reserved" means that the bit is not guaranteed to be any particular value. Reserved bits should not be used for any purpose.

9.1.1 Fault messages

WARNING 1, 10 volts low

The control card voltage is below 10 V from terminal 50. Remove some of the load from terminal 50, as the 10 V supply is overloaded. Max. 15 mA or minimum 590 Ω.

WARNING/ALARM 2, Live zero error

The signal on terminal 53 or 54 is less than 50% of the value set in par. 6-10, 6-12, 6-20 or 6-22 respectively.

WARNING/ALARM 4, Mains phase loss

A phase is missing on the supply side, or the mains voltage imbalance is too high.

WARNING 5, DC link voltage high

The intermediate circuit voltage (DC) is higher than the high voltage warning limit. The unit is still active.

WARNING 6, DC link voltage low

The intermediate circuit voltage (DC) is below the under-voltage limit of the control system. The unit is still active.

WARNING/ALARM 7, DC overvoltage

If the intermediate circuit voltage exceeds the limit, the unit trips.

WARNING/ALARM 8, DC under voltage

If the intermediate circuit voltage (DC) drops below the under voltage limit, the filter checks if a 24 V backup supply is connected. If not, the unit trips. Check that the mains voltage matches the nameplate specification.

WARNING/ALARM 13, Over Current

the unit current limit has been exceeded.

ALARM 14, Earth (ground) fault

There is a discharge from the output phases to earth. Turn off the unit and correct the earth fault.

ALARM 15, Incomp. Hardware

A mounted option is not handled by the present Control Card SW / HW.

ALARM 16, Short circuit

There is a short-circuit in the output. Turn off the unit and correct the error.

WARNING/ALARM 17, Control word timeout

There is no communication to the unit.

The warning will only be active when par. 8-04 *Control Word Timeout Function* is NOT set to OFF.

Possible correction: Increase par. 8-03. Change par. 8-04

WARNING 23, Internal fan fault

Internal fans have failed due to defect hardware or fans not mounted.

WARNING 24, External fan fault

External fans have failed due to defect hardware or fans not mounted.

ALARM 29, Heatsink temp

The maximum temperature of the heatsink has been exceeded. The temperature fault will not be reset until the temperature falls below a defined heatsink temperature.

ALARM 33, Inrush fault

Check whether a 24 Volt external DC supply has been connected.

WARNING/ALARM 34, Fieldbus communication fault

The fieldbus on the communication option card is not working.

WARNING/ALARM 35, Option Fault:

Contact your supplier.

ALARM 38, Internal fault

Contact your Danfoss supplier.

ALARM 39, Heatsink sensor

No feedback from the heatsink temperature sensor.

WARNING 40, Overload of Digital Output Terminal 27

Check the load connected to terminal 27 or remove short-circuit connection.

WARNING 41, Overload of Digital Output Terminal 29

Check the load connected to terminal 29 or remove short-circuit connection.

WARNING 42, Overload of Digital Output on X30/6 or Overload of Digital Output on X30/7

For X30/6, check the load connected to X30/6 or remove short-circuit connection.

For X30/7, check the load connected to X30/7 or remove short-circuit connection.

WARNING 43, Ext. Supply (option)

The external 24 V DC supply voltage on the option is not valid.

ALARM 46, Power card supply

The supply on the power card is out of range.

WARNING 47, 24 V supply low

Contact your Danfoss supplier.

WARNING 48, 1.8 V supply low

Contact your Danfoss supplier.

WARNING/ALARM/TRIP 65, Control card over temperature

Control card over temperature: The cutout temperature of the control card is 80° C.

WARNING 66, Heatsink temperature low

This warning is based on the temperature sensor in the IGBT module.

Troubleshooting:

The heatsink temperature measured as 0° C could indicate that the temperature sensor is defective causing the fan speed to increase to the maximum. If the sensor wire between the IGBT and the gate drive card is disconnected, this warning would result. Also, check the IGBT thermal sensor.

ALARM 67, Option module configuration has changed

One or more options have either been added or removed since the last power-down.

ALARM 68, Safe stop activated

Safe stop has been activated. To resume normal operation, apply 24 VDC to terminal 37, then send a reset signal (via Bus, Digital I/O, or by pressing the reset key. See parameter 5-19, Terminal 37 Safe Stop.

ALARM 69, Power card temperature

The temperature sensor on the power card is either too hot or too cold.

ALARM 70, Illegal FC Configuration

Actual combination of control board and power board is illegal.

WARNING 73, Safe stop auto restart

Safe stopped. Note that with automatic restart enabled, the motor may start when the fault is cleared.

WARNING 77, Reduced power mode:

This warning indicates that the drive is operating in reduced power mode (i.e. less than the allowed number of inverter sections). This warning will be generated on power cycle when the drive is set to run with fewer inverters and will remain on.

ALARM 79, Illegal power section configuration

The scaling card is the incorrect part number or not installed. Also MK102 connector on the power card could not be installed.

ALARM 80, Unit initialized to default value

Parameter settings are initialized to default settings after a manual reset.

ALARM 244, Heatsink temperature

Report value indicates source of alarm (from left):

- 1-4 Inverter
- 5-8 Rectifier

ALARM 245, Heatsink sensor

No feedback from the heatsink sensor. Report value indicates source of alarm (from left):

- 1-4 Inverter
- 5-8 Rectifier

ALARM 246, Power card supply

The supply on the power card is out of range Report value indicates source of alarm (from left):

- 1-4 Inverter
- 5-8 Rectifier

ALARM 247, Power card temperature

Power card over temperature Report value indicates source of alarm (from left):

- 1-4 Inverter
- 5-8 Rectifier

ALARM 248, Illegal power section configuration

Power size configuration fault on the power card Report value indicates source of alarm (from left):

- 1-4 Inverter
- 5-8 Rectifier

ALARM 249, Rect. low temp.

The temperature of the rectifier heat sink is too low. This could indicate that the temperature sensor is defect.

ALARM 250, New spare part

The power or switch mode power supply has been exchanged. The filter type code must be restored in the EEPROM. Select the correct type code in par. 14-23 *Typecode Setting* according to the label on the unit. Remember to select 'Save to EEPROM' to complete.

ALARM 251, New type code

The filter has a new type code.

ALARM 300, Mains Cont. Fault

The feedback from the mains contactor did not match the expected value within the allowed time frame. Contact your supplier.

ALARM 301, SC Cont. Fault

The feedback from the soft charge contactor did not match the expected value within the allowed time frame. Contact your supplier.

ALARM 302, Cap. Over Current

Excessive current was detected through the AC capacitors. Contact your supplier.

ALARM 303, Cap. Earth Fault

An earth fault was detected through the AC capacitor currents. Contact your supplier.

ALARM 304, DC Over Current

Excessive current through the DC link capacitor bank was detected. Contact your supplier.

ALARM 305, Mains Freq. Limit

The mains frequency was outside the limits. Verify that the mains frequency is within product specification.

ALARM 306, Compensation Limit

The needed compensation current exceeds unit capability. Unit is running at full compensation.

ALARM 308, Resistor temp

Excessive resistor heatsink temperature detected.

ALARM 309, Mains Earth Fault

An earth fault was detected in the mains currents. Check the mains for shorts and leakage current.

ALARM 310, RTDC Buffer Full

Contact your supplier.

ALARM 311, Switch. Freq. Limit

The average switching frequency of the unit exceeded the limit. Verify that parameters 300-10 and 300-22 are set correctly. If so, contact your supplier.

ALARM 312, CT Range

Current transformer measurement limitation was detected. Verify that the CTs used are an appropriate ratio.

ALARM 314, Auto CT Interrupt

Auto CT detection was interrupted by the user.

ALARM 315, Auto CT Error

An error was detected while performing auto CT detection. Contact your supplier.

ALARM 316, CT Location Error

The Auto CT function could not determine the correct locations of the CTs.

ALARM 317, CT Polarity Error

The Auto CT function could not determine the correct polarity of the CTs.

ALARM 318, CT Ratio Error

The Auto CT function could not determine the correct primary rating of the CTs.



www.danfoss.com/drives

Danfoss can accept no responsibility for possible errors in catalogues, brochures and other printed material. Danfoss reserves the right to alter its products without notice. This also applies to products already on order provided that such alterations can be made without subsequential changes being necessary in specifications already agreed. All trademarks in this material are property of the respective companies. Danfoss and the Danfoss logotype are trademarks of Danfoss A/S. All rights reserved.

